

# LETTER TO FAMILY

.....

*Cut here and paste onto school letterhead before making copies.*

---

## Science News

---

Dear Family,

Our class is beginning a study of air and weather. Students will be looking for evidence that air is matter—that it is something real. Students will explore the properties of air using plastic syringes and tubing. They will observe how air can be captured, how air can be compressed, and how air under pressure can move things around. Students will observe daily weather conditions such as temperature, rainfall, cloud cover, wind speed, and wind direction. They will be recording all this information on a class calendar and in a science notebook. Students will also observe and record daily changes in the appearance of the Moon over a month. Students will be observing the Moon during the daylight hours and at home during the evening.

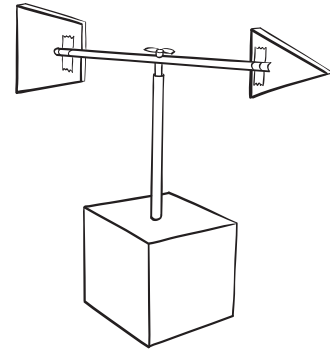

You can help your child learn more about weather, too. You might discuss weather reports in the newspaper, on the Internet, or on television. Point out wind vanes if you happen to see one perched on top of a house. If you have an indoor or outdoor thermometer, read and record the temperature at about the same time each day and look for patterns. Or you may want to watch the temperature change over the course of one day. Does it happen that way every day? Weather is an ever-changing story. You can guide your child's scientific inquiry by helping him or her to make observations and by nurturing his or her natural ability to ask questions based on those observations. Don't be surprised if you end up with a list of questions much longer than the initial observations.

If you have any questions or comments, call or come in and visit our class. You can get more information on this module by going to [www.FOSSweb.com](http://www.FOSSweb.com).

Sincerely,

