



LAB NOTEBOOK

Table of Contents

Investigation 1: Here to There

Terms, Definitions, and Symbols	1
Equations	3
Air-Trolley Construction	5
Flight Distances	7
Air-Trolley Distance Graph.....	9
Road Races A	10
Road Races B.....	11

Investigation 2: Speed

Who Got There First? (race 1).....	13
Who Got There First? (race 2).....	14
Who Got There First? (race 3).....	15
Time Travel A.....	16
Time Travel B	17
Speed and Distance Practice A	18
Speed and Distance Practice B	19
Response Sheet—Speed	21
Speeding Down Slopes.....	23
Average Speed Practice A	24
Average Speed Practice B.....	25

Investigation 3: Comparing Speeds

Walk and Run Speeds.....	26
Walk/Run Races.....	27
Photo Finish Results	29
Boat Speed	30
Boat-Speed Graphs	31
Response Sheet—Comparing Speeds	33
Iditarod	35

Investigation 4: Representing Motion

Show Time A.....	36
Show Time B.....	37
Clancey’s Afternoon A.....	38
Clancey’s Afternoon B.....	39
Leisurely Walks.....	41
Road Trip.....	42
Road-Trip Graphs.....	43
Response Sheet—Representing Motion.....	45
Graph a Motion Event.....	46
Create a Motion Story.....	47

Investigation 5: Acceleration

Comparing Tracks A.....	48
Comparing Tracks B.....	49
Rolling Dotcar.....	51
X Car and Z Car A.....	52
X Car and Z Car B.....	53
Dotmaker A.....	54
Dotmaker B.....	55
Response Sheet—Acceleration.....	57
Acceleration Practice A.....	58
Acceleration Practice B.....	59
Cars and Loads A.....	60
Cars and Loads B.....	61

Investigation 6: Force

Pusher Assembly.....	63
Pushes and Pulls A.....	64
Pushes and Pulls B.....	65
Pushes and Pulls C.....	66
Force and Sleds.....	67
Forces on Carts A.....	68
Forces on Carts B.....	69
Response Sheet—Force.....	71
Force Bench Experiments.....	73

Investigation 7: Gravity

Life-Raft Drop A.....	74
Life-Raft Drop B.....	75
Calculating Velocity and Distance.....	76
Velocity and Distance Practice.....	77
Response Sheet—Gravity.....	79
Testing Galileo’s Rule.....	81

Investigation 8: Momentum

Runaway Float A.....	82
Runaway Float B.....	83
Float Momentum A.....	84
Float Momentum B.....	85
Car Crashes.....	87
Response Sheet—Momentum.....	89
Equations.....	90

Name _____

Period _____ Date _____

EQUATIONS

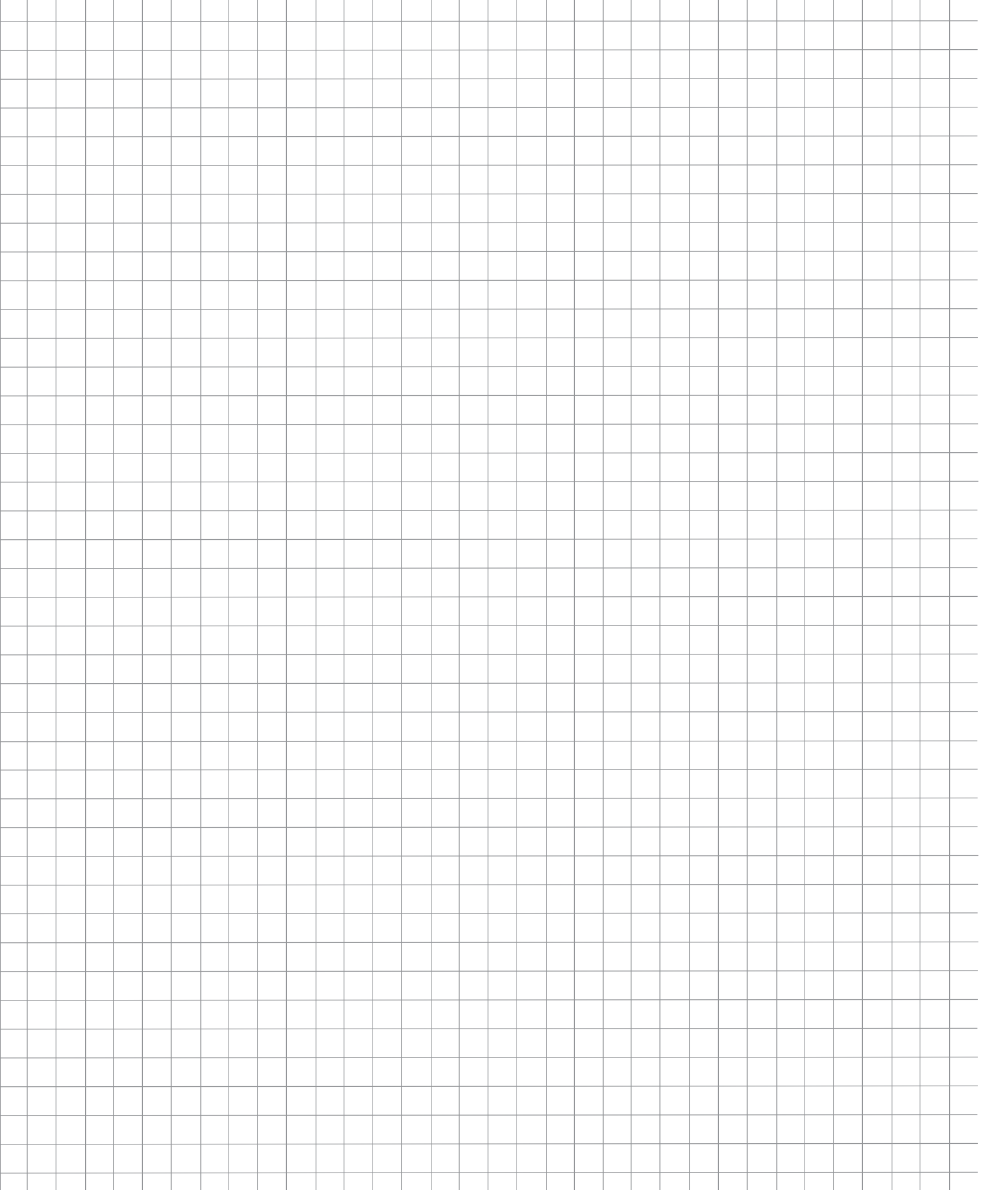

AIR-TROLLEY CONSTRUCTION

Materials

- | | |
|---------------------|-------------------------------|
| 1 Jumbo straw | 1 Rubber band |
| 1 Super jumbo straw | 1 Meter tape |
| 1 Index card | 1 Scissors |
| 1 Propeller | • Transparent tape |
| 1 Hook | • Clear packing tape, 2" wide |

- a. Cut the super jumbo straw (larger diameter) at 11 cm.



Cut the jumbo straw at 15 cm.

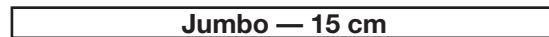

- b. Fold the index card in half. Tape the edge.

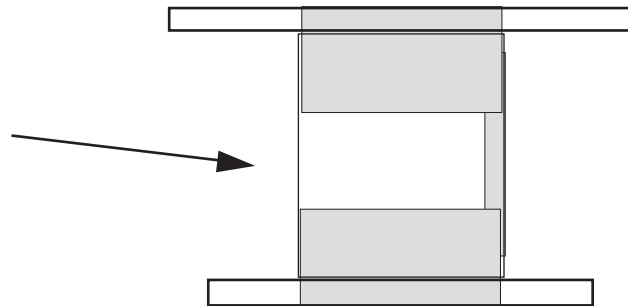
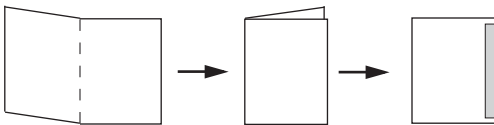

- c. Use the wider clear packing tape for this assembly. Center everything before taping. Tape the two straw pieces to the short edges of the folded card.

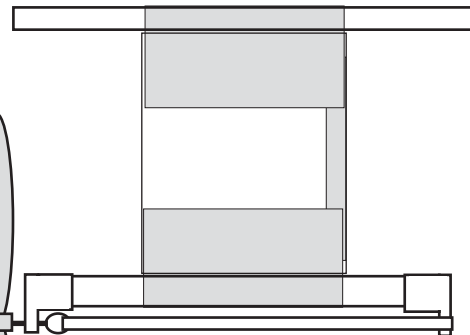

- d. Attach a propeller to one end of the super jumbo straw and a hook to the other end. Connect the propeller and hook with the rubber band.



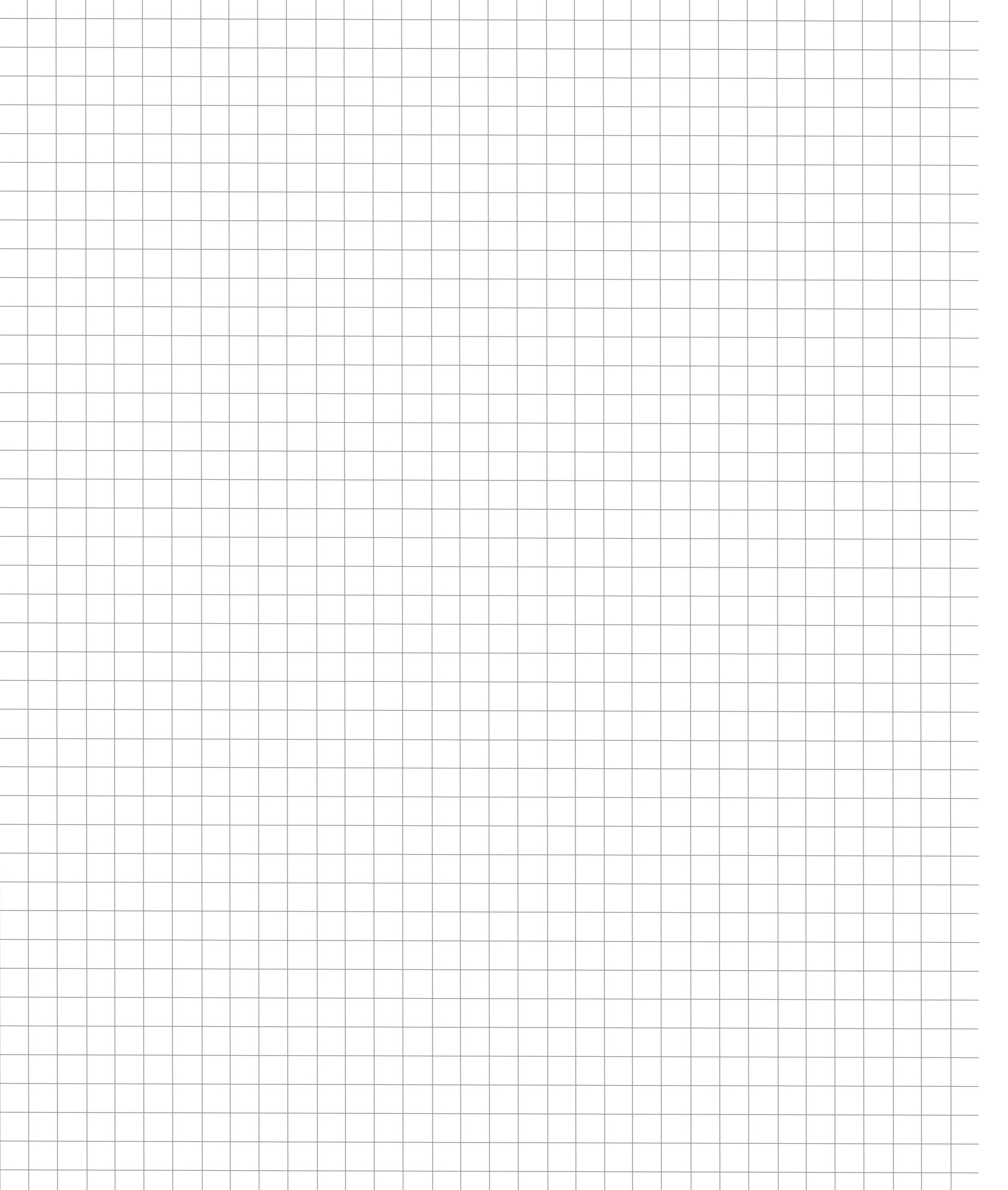

FLIGHT DISTANCES

How far did each air trolley fly? Calculate the distance of each flight, using the distance equation. Mark your reference points with arrows and show your math.

Flight 1

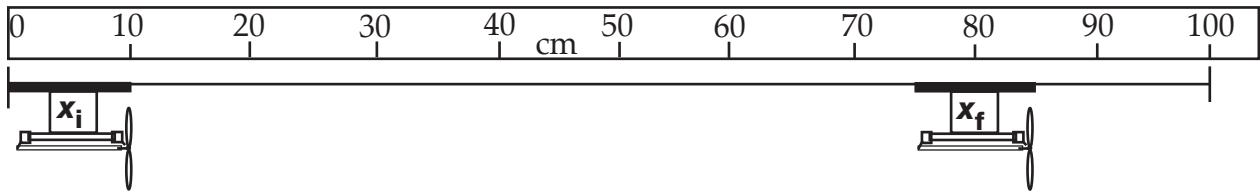

Flight 2

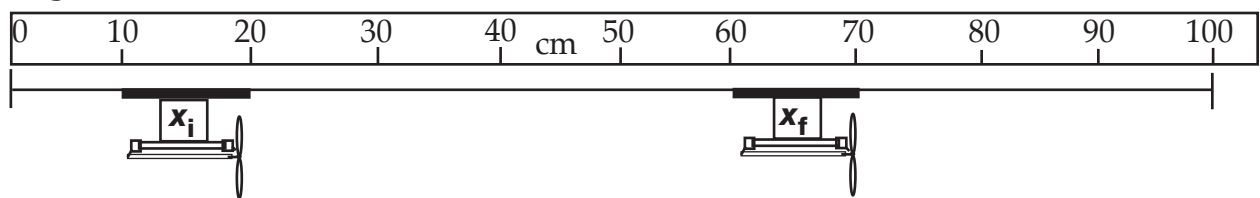

Flight 3

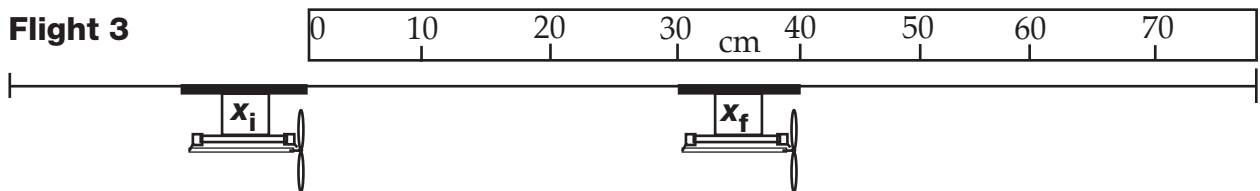

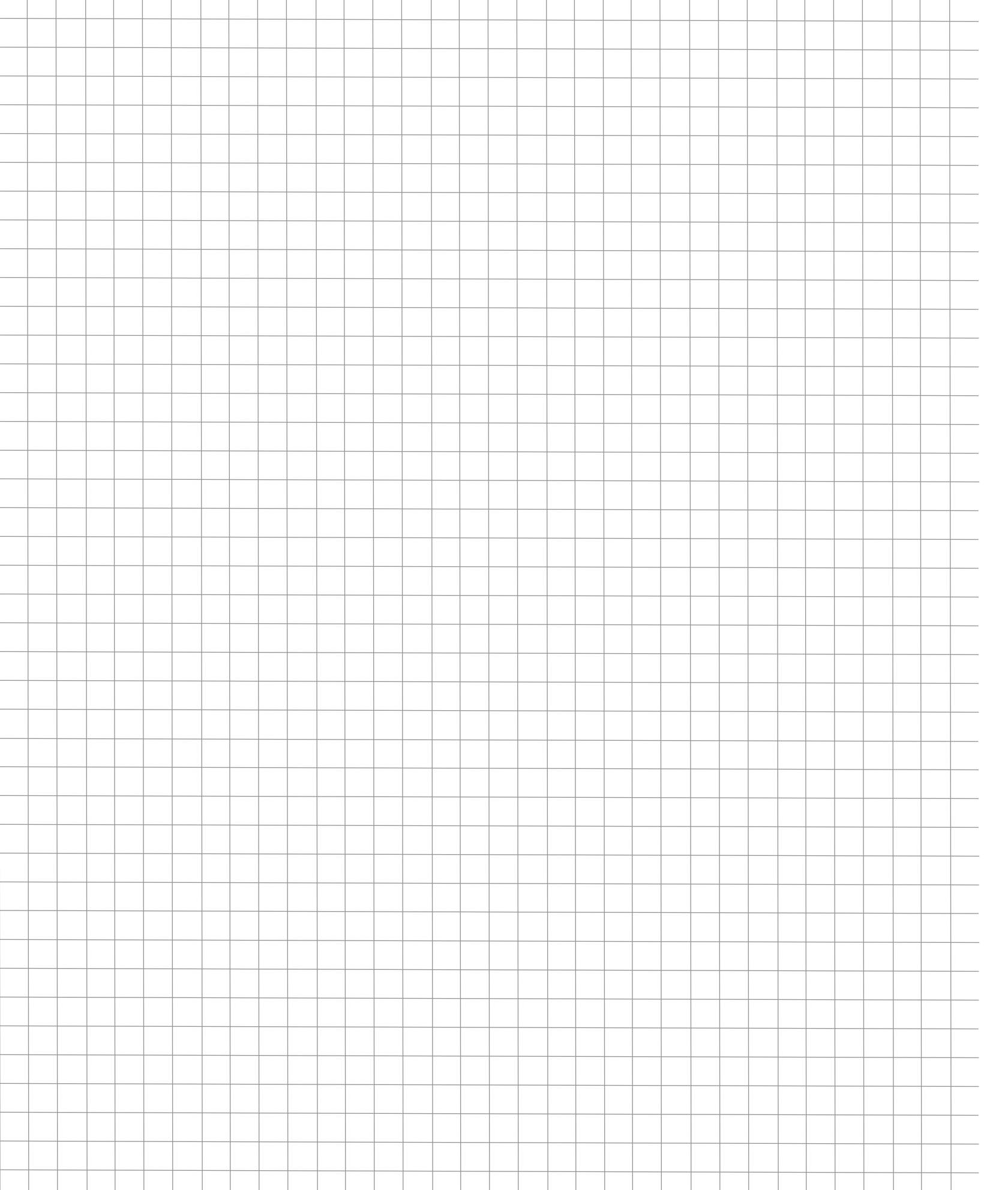

AIR-TROLLEY DISTANCE GRAPH

Part 1: Gather air-trolley flight data.

1. Number of winds on the propeller _____
2. Measured flight distances during five trials

Trial	Distance (cm)

3. Average flight distance

Part 2: Graph the air-trolley flight data.

Title _____

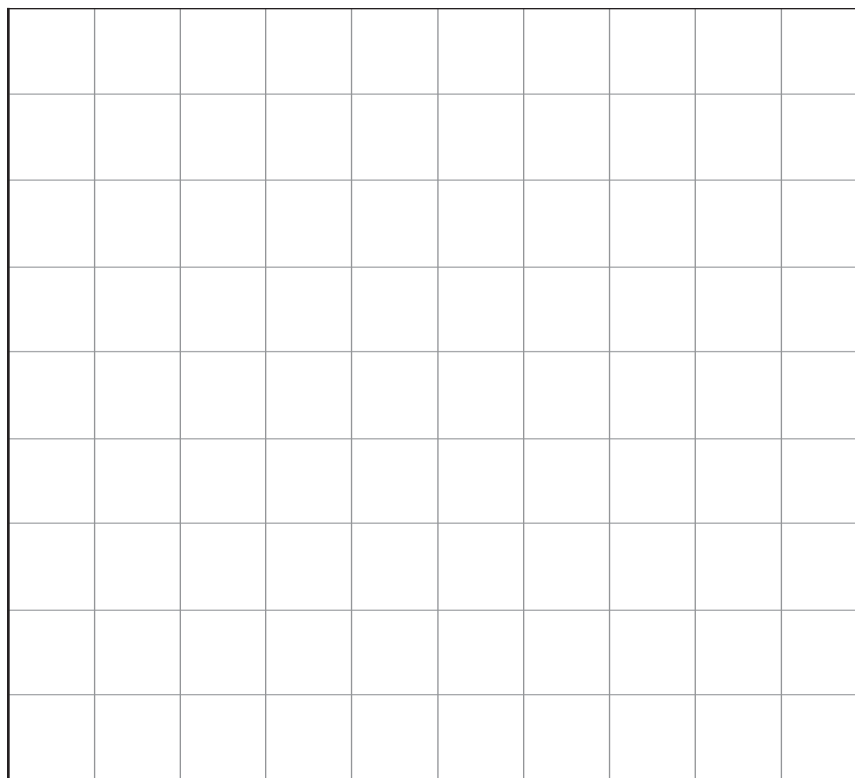

Winds	d (cm)

Name _____

Period _____ Date _____

ROAD RACES A

Write the equation for calculating distance. _____

Road Race 1 One person drove a car, and the other rode a pogo stick.

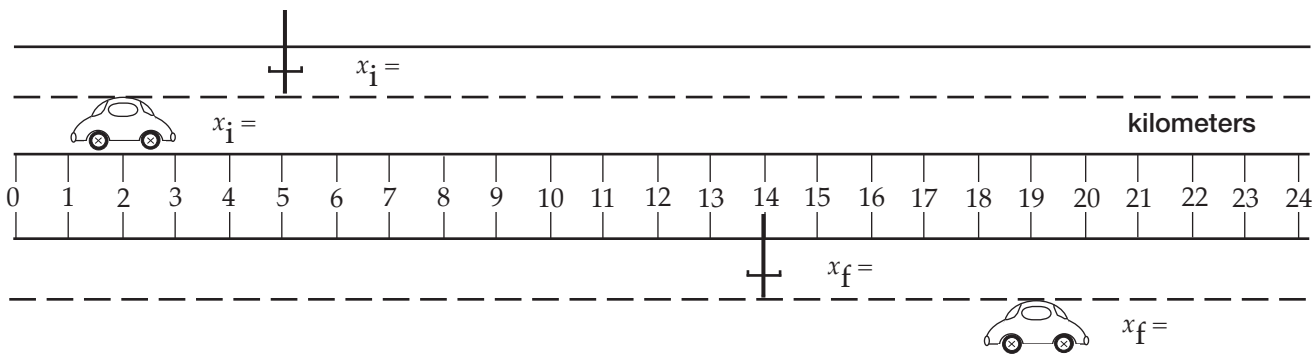

Which vehicle went farther?

Pogo-stick math here.

Car math here.

How much farther?

Difference math here.

Road Race 2 One person drove a truck, and the other drove a car.

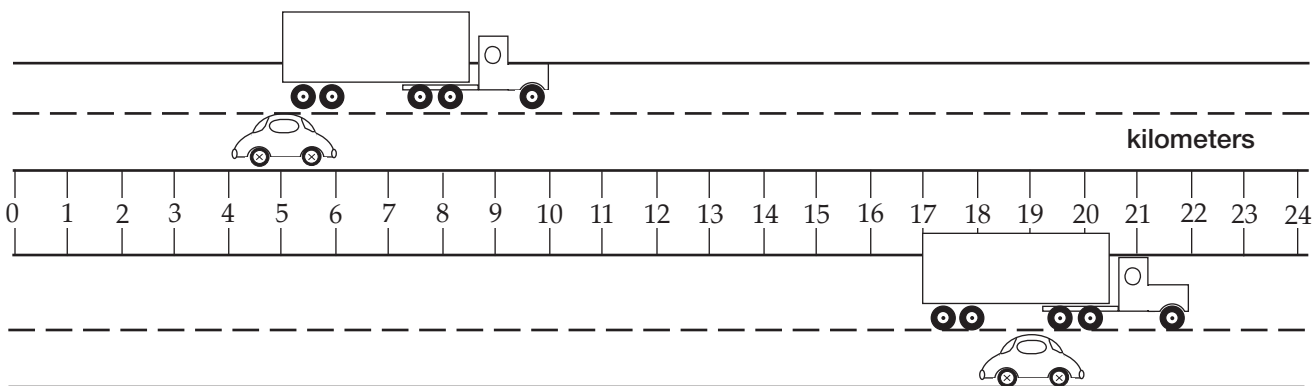

Which vehicle went farther?

Math here.

How much farther?

Math here.

ROAD RACES B

Road Race 3

One person started in a car, ran out of gas, and finished on a pogo stick. The other person drove a truck.

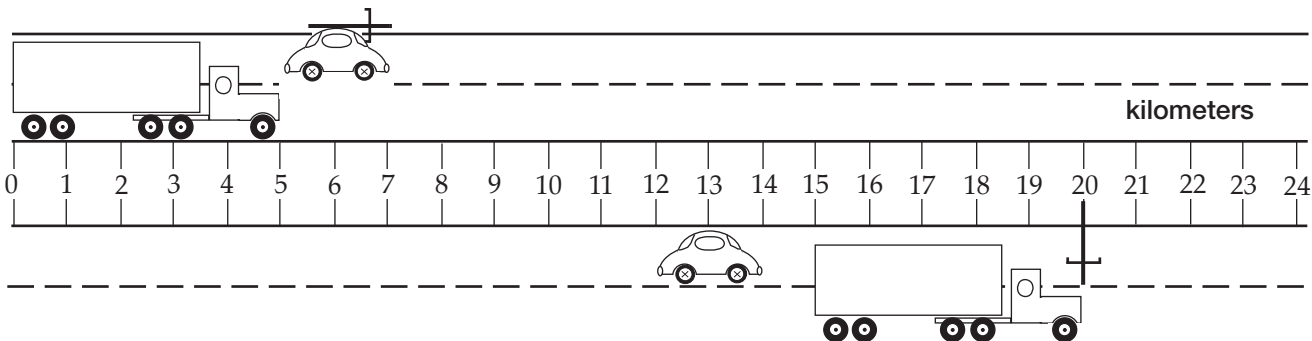

Which of the three vehicles went the greatest distance?

Which vehicle went the shortest distance?

Math here.

Road Race 4

A truck hauling car A raced against car B.

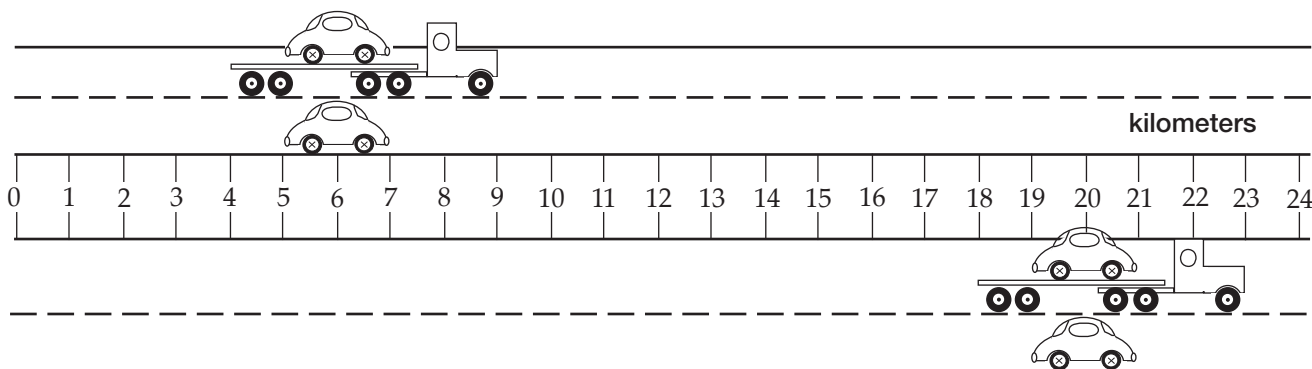

Which of the three vehicles went farthest?

How much farther?

Math here.

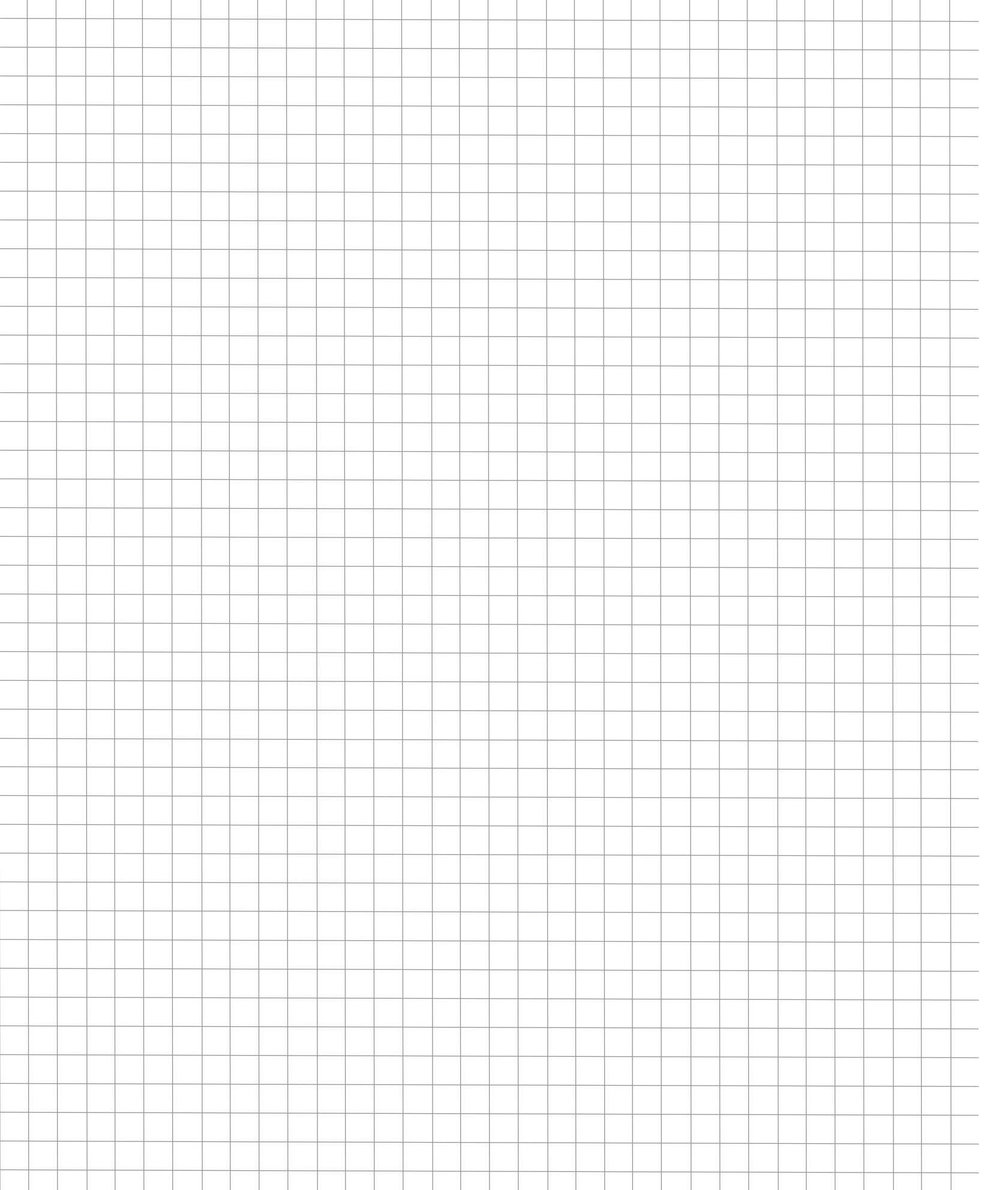

WHO GOT THERE FIRST? (race 1)

Look at race 1 between the truck and car.
 Neither of the vehicles changed speed during the race.
 Which vehicle reached the 150-kilometer mark first?

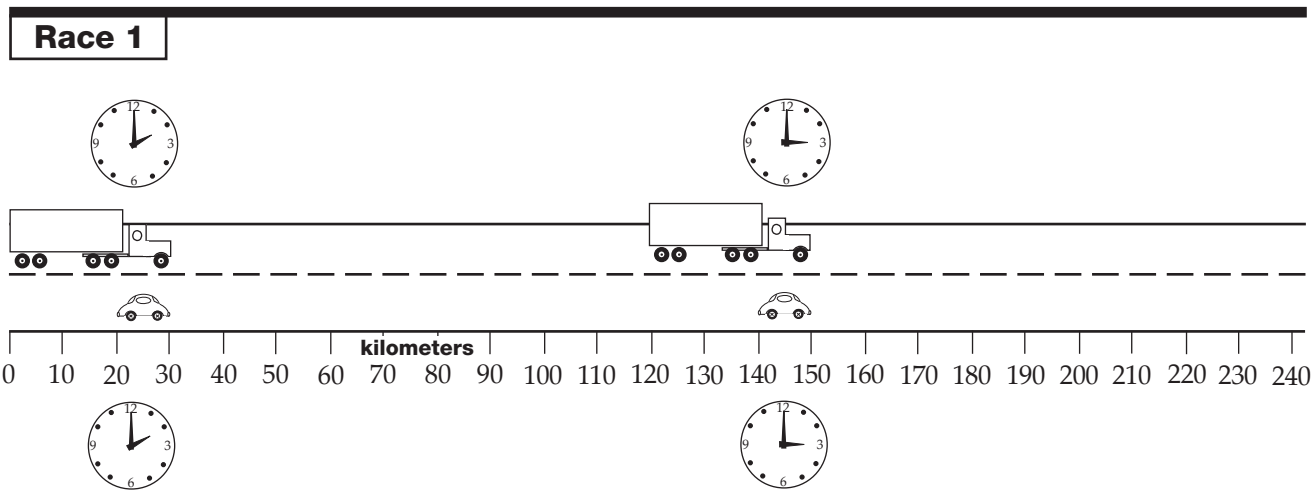

Truck $d =$ _____ Truck time interval = _____

Car $d =$ _____ Car time interval = _____

Which vehicle reached the 150-km mark first? _____

How do you know? _____

Show math here.

Name _____

Period _____ Date _____

WHO GOT THERE FIRST? (race 2)

Look at race 2 between the truck and car.

Neither of the vehicles changed speed during the race.

Which vehicle reached the 150-kilometer mark first?

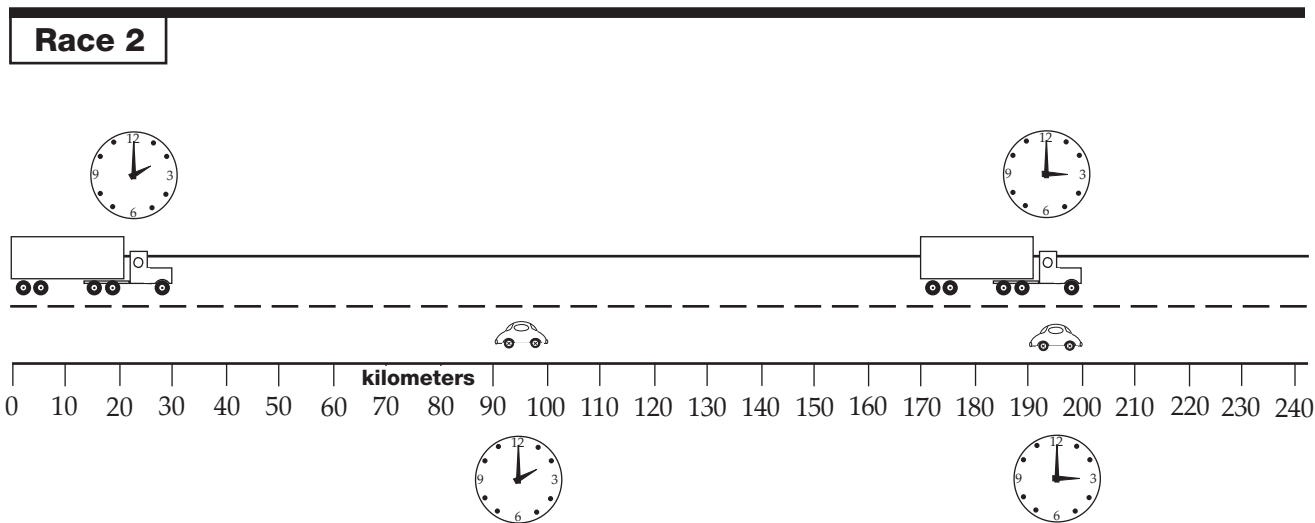

Truck $d =$ _____ Truck time interval = _____

Car $d =$ _____ Car time interval = _____

Which vehicle reached the 150-km mark first? _____

How do you know? _____

Show math here.

WHO GOT THERE FIRST? (race 3)

Look at race 3 between the truck and car.

Neither of the vehicles changed speed during the race.

Which vehicle reached the 150-kilometer mark first?

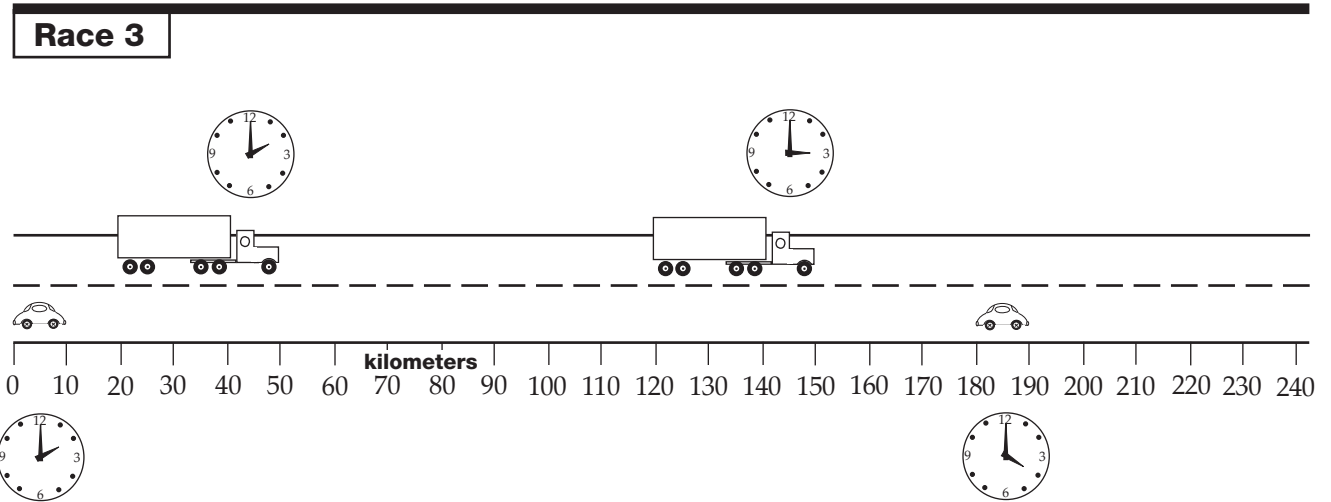

Truck $d =$ _____ Truck time interval = _____

Car $d =$ _____ Car time interval = _____

Which vehicle reached the 150-km mark first? _____

How do you know? _____

Show math here.

TIME TRAVEL A

1. At 2:30 p.m. a car and a truck were in the positions shown at x_i . At 3:30 p.m. the car and truck were in the positions shown at x_f . They traveled at steady speed all the time.

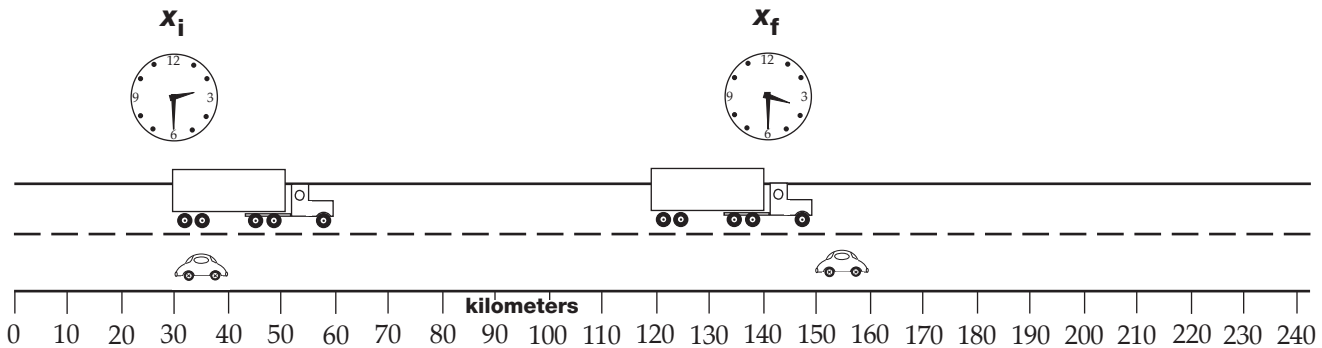

Show math and units in these boxes.

a. How far did each vehicle travel?

Truck _____

Car _____

b. How long did it take the vehicles to get to their positions at x_f ?

c. How fast was each vehicle going from x_i to x_f ?

d. What is the equation for calculating **speed**?

e. Which vehicle got to the 100-km mark first?

How do you know?

TIME TRAVEL B

2. This time the vehicles started at the positions shown at x_i , but the truck was going **half as fast** as it was in problem 1.

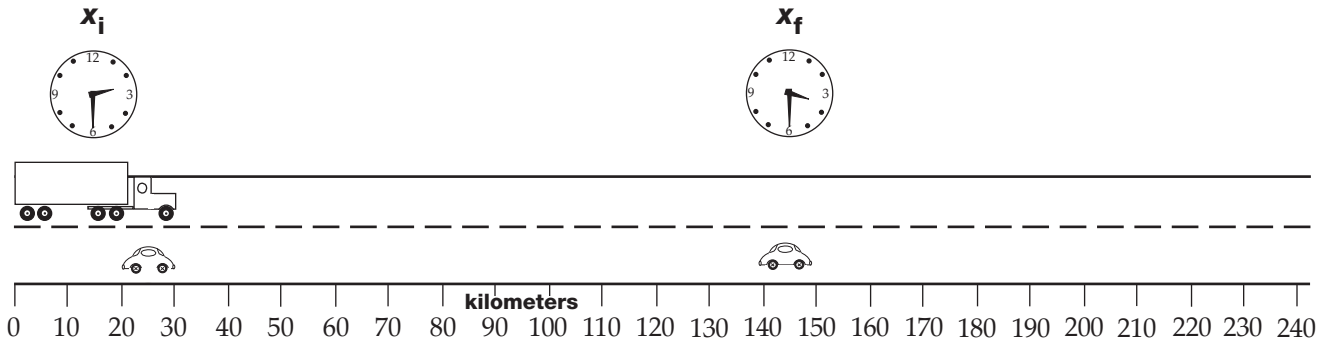

Show math and units in these boxes.

a. Where would the **truck** be at 3:30 p.m.?

b. How far would the **truck** have traveled at 9:30 p.m.?

c. How far would the **car** have traveled at 3:00 p.m.?

d. What is the equation for calculating **distance when you know the speed and time?**

e. What is the total distance traveled by **both vehicles** (added together) at 5:00 p.m.?

SPEED AND DISTANCE PRACTICE A

- Bonnie rode her skateboard 200 meters (m) in 30 seconds (s). Raul rode his unicycle 300 m in 50 s. Who traveled faster? How much faster?
- It is about 384,750 kilometers (km) from Earth to the Moon. It took the Apollo astronauts about 2 days and 19.5 hours to fly to the Moon. How fast did they travel?
- A chipmunk can run 5 m/s. A fox can run 8 m/s. If the chipmunk and fox start running at the same time, will the chipmunk make it to its burrow in time?

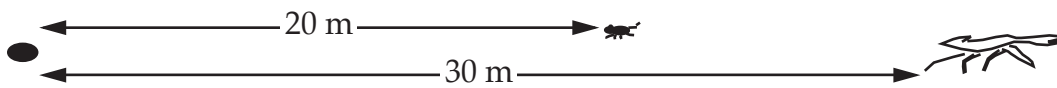

- Rita flew from Los Angeles to Boston to visit her aunt, a distance of 4000 km. The trip took 5 hours (h). What was the average speed of the jet?
- A truck left a diner at 1:00 p.m. and drove 360 km to Jersey City. The truck arrived at 7:00 p.m. A car left the same diner at 2:00 p.m. and drove to Jersey City at an average speed of 80 km/h.
 - How fast did the truck travel?
 - Which vehicle got to Jersey City first?
- An Arctic tern can fly 85 km/h for 24 h straight. How far can it fly before landing?
- Rosita started riding her bike 3 km to her friend Gena's place at exactly the same time Gena started skating to Rosita's house. Gena, of course, wasn't home, so Rosita rode back home. The two girls arrived at Rosita's house at the same time. It took Rosita 30 minutes to ride to Gena's and back. How fast did Gena skate?

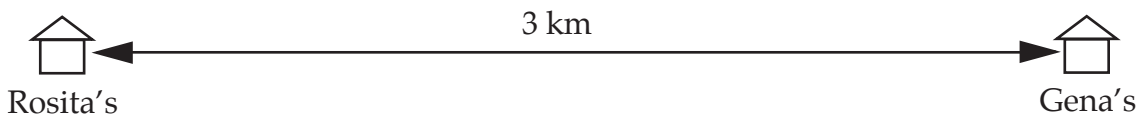

SPEED AND DISTANCE PRACTICE B

8. A hiker wanted to hike to a lake 26 km from the end of the road. She started at 6 a.m. and walked steadily until 9:00 a.m. She stopped for a 1-hour rest and then continued until she stopped for 1.5 h to have lunch. She took only one 0.5 h rest in the afternoon and arrived at the lake at 7:00 p.m.
- What was the hiker's average speed from the end of the road to the lake?
 - What was the hiker's average speed during the time she was actually hiking?
9. Ron put 16 gallons (gal.) of gas in his truck and reset the trip odometer to 0. He drove until he ran out of gas. The odometer read 480 km. How many kilometers per gallon does Ron's truck get?
10. Beth's motor scooter gets 110 km/gal. How far can she go on 2.5 gal. of fuel?
11. A champion jumping frog can jump 2.5 m every 4 s. What is the jumping frog's average speed?
12. An ostrich can run 10 km in 15 minutes. What is its speed in kilometers/hour?
13. A basketball rolled 300 m down a hill in 25 s. What was its average speed down the hill?
14. A commuter got on the train at the Oakdale Station at 6:50 a.m. She got off at Metro Station at 8:05 a.m. The train made five 3-minute stops along the way. Oakdale is 21 km from the end of the line, and Metro Station is 96 km from the end of the line.
- What was the commuter's average speed getting to work?
 - What was the average speed of the train while it was under way?

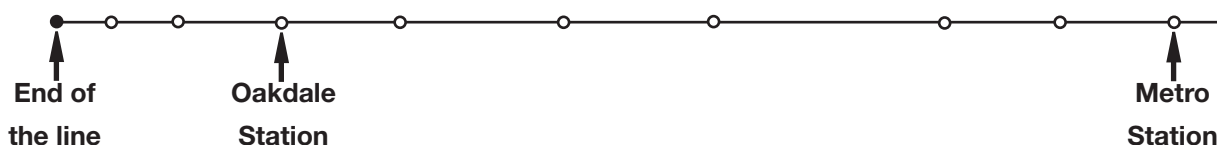

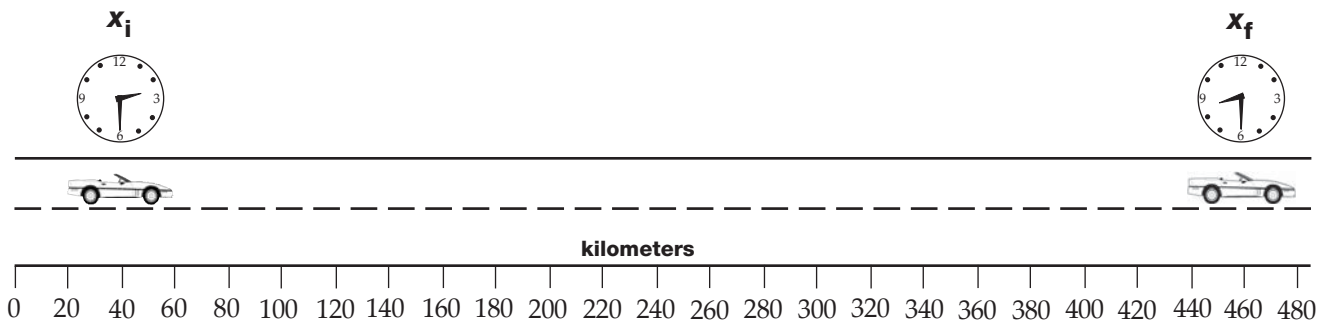
RESPONSE SHEET—SPEED

Abbi looked at the representation of the road trip shown above and said,

I know how far the car went and how long it took to get there, but I'm not sure how fast it went.

Gwen said,

Here, I'll show you how to figure out how fast the car was going.

1. What do you think Gwen showed Abbi?

2. Show Abbi and Gwen how to figure out how far the car had gone after 2.5 hours.

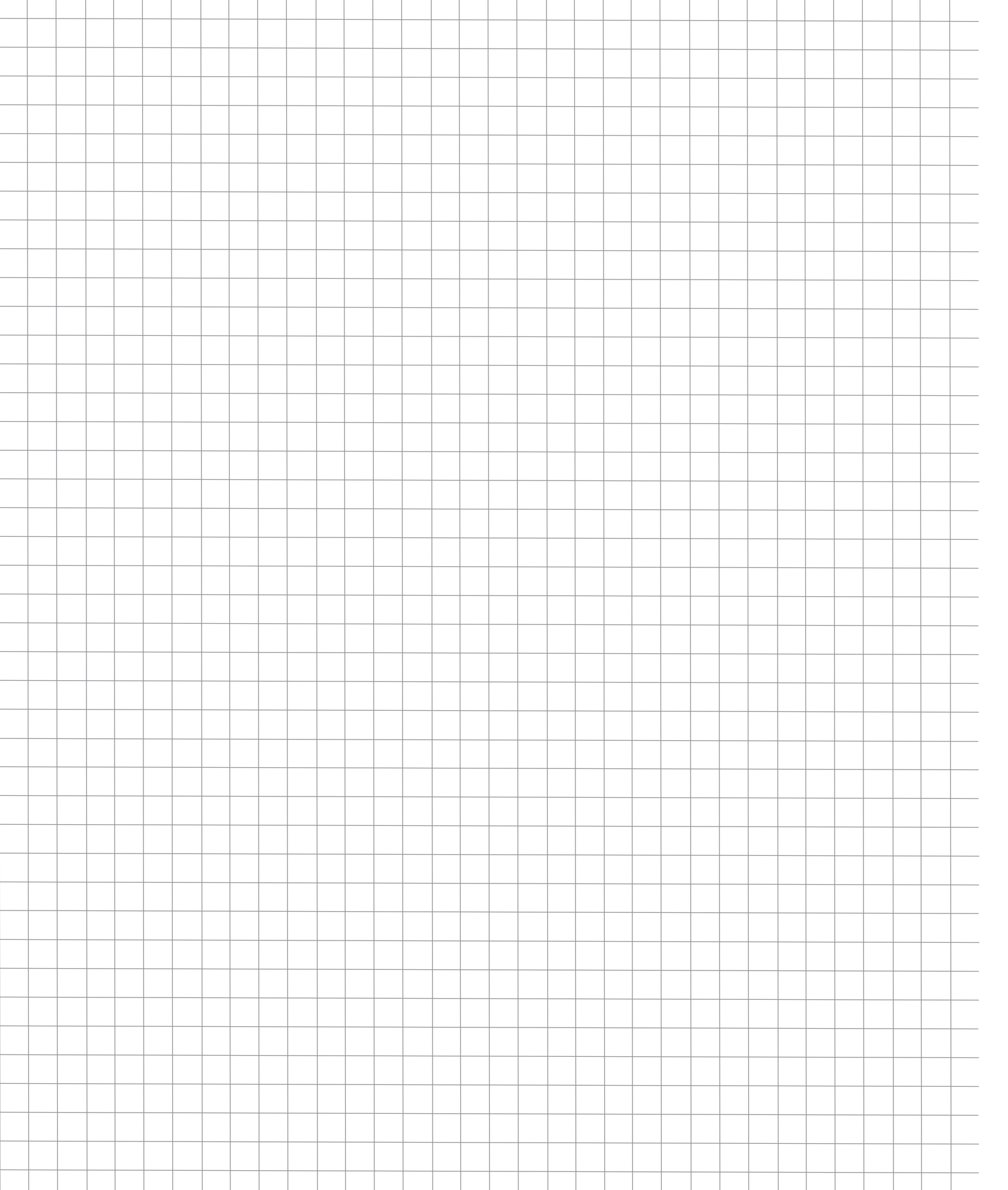

AVERAGE SPEED PRACTICE A

- When Belinda walks to school in the morning, it takes her 12 minutes to walk the 1 kilometer (km). When she walks home after school with her little sister, it takes twice as long. Does Belinda's speed increase or decrease when she walks with her sister?
- Frank's car rolled 300 centimeters (cm) in 1.5 seconds (s).
Noah's car rolled 360 cm in 2 s.
Whose car ran on a steeper ramp?
- A biker rode up a 20-km hill in 2 hours and down the hill in 0.5 hour without stopping. What was his average speed
 - going up the hill?
 - going down the hill?
 - for the whole trip?
- It took Ellie 4 hours to paddle her canoe 10 km upstream. After a leisurely 3-hour picnic, she paddled back home in 1 hour.
 - How fast did Ellie paddle upstream?
 - What was Ellie's average speed while she was paddling her canoe?
- Mark's family drove 180 km to the beach at 90 km/h. They drove home at 60 km/h. What was their average driving speed for the time they were on the road?

- Three girls raced their model cars down a 40-meter track. Their times are in the table. What was the average speed at which the cars rolled down the track?

	Δt (s)	d (m)
Jessica	10	40
Kristi	20	40
Laticia	8	40

- Ben took off in a plane at 9:30 a.m. from Seattle and landed in Baltimore, 4030 km away, at 7:00 p.m. There was a 1.5-hour layover in Denver. (The time in Baltimore is 3 hours later than in Seattle.)
 - What was Ben's average speed on his trip from Seattle to Baltimore?
 - What was the plane's average speed while in the air?

AVERAGE SPEED PRACTICE B

8. A high school varsity hardball pitcher can throw his fastball 28.5 m in 0.75 s. A high school varsity softball pitcher can throw her fastball 12.0 m in 0.3 s. Which pitcher's ball travels faster?
9. A boat sailed out to an island at a speed of 18 km/h in 4 h and then immediately sailed back to port at 36 km/h in 2 h. What was its average speed for the trip?

10. Sweta entered a skate, row, and bike race. Her time and distance for each leg of the race are entered in the chart.

- a. What was Sweta's average speed for each leg?
- b. What was her average speed over the whole race?

	Δt (h)	d (km)	v (km/h)
Skate	1.25	20	
Row	0.75	6	
Bike	2.5	100	

11. Biff's dog loves to catch his tennis ball. It takes the ball 5 s to fly 60 m.
- a. How fast does Biff's dog have to run to catch it?
- b. How fast is that in kilometers per hour?
12. Lily's family took a motor boat 24 km down a river for a picnic. It took them 1 h to get to the picnic spot. The ride back to the dock took an hour and a half.
- a. What was the boat's average speed going to the picnic?
- b. What was the boat's average speed coming home from the picnic?
- c. What was the boat's average speed for the whole boat ride to and from the picnic?
- d. What was the average speed at which the river flowed?
- e. What would the boat's average speed be on a lake?
13. What is the average speed of an arrow that takes 1.25 s to hit a target 75 m away?

Name _____

Period _____ Date _____

WALK AND RUN SPEEDS

- a. Write the name of your group's walker and runner in the tables.
- b. Record the distance that will be traveled.
- c. Time three walks and three runs. Record the times in the tables.

Walker's name	Δt_1 (s)	Δt_2 (s)	Δt_3 (s)	Δt_{av} (s)	d (m)

Runner's name	Δt_1 (s)	Δt_2 (s)	Δt_3 (s)	Δt_{av} (s)	d (m)

- d. Calculate the **average time** for the walker and for the runner.
- e. Calculate the **average speed** for the walker and the runner. Show your math.
- f. Graph the average walking speed and the average running speed on this grid.

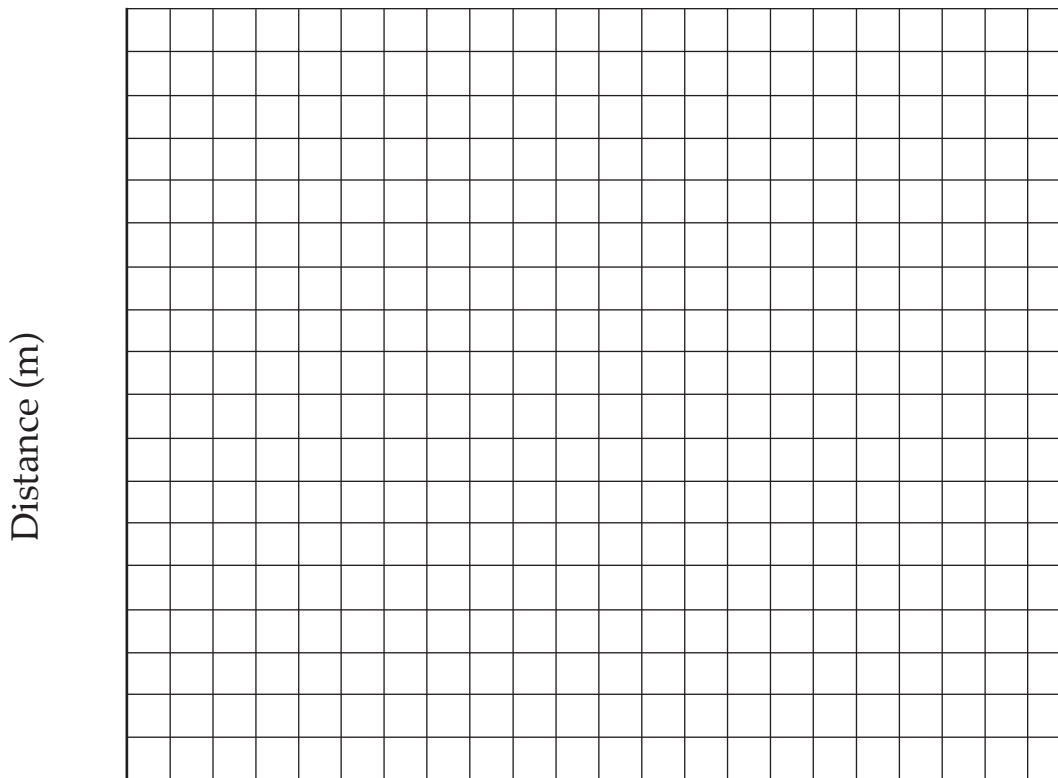

WALK/RUN RACES

Your walker and your runner will have a race. These are the objective and rules.

Objective: The walker and runner should cross the finish line at the same time.

Rules

- The race distance is 20 meters.
- The walker and runner must maintain constant speed. Don't slow down or speed up.
- You can use a **time** head start or a **distance** head start to achieve your objective.

20-meter race

Walker's name	Starting position	Starting time	Δt (s)	d (m)

Runner's name	Starting position	Starting time	Δt (s)	d (m)

10-meter race (optional)

Walker's name	Starting position	Starting time	Δt (s)	d (m)

Runner's name	Starting position	Starting time	Δt (s)	d (m)

40-meter race (optional)

Walker's name	Starting position	Starting time	Δt (s)	d (m)

Runner's name	Starting position	Starting time	Δt (s)	d (m)

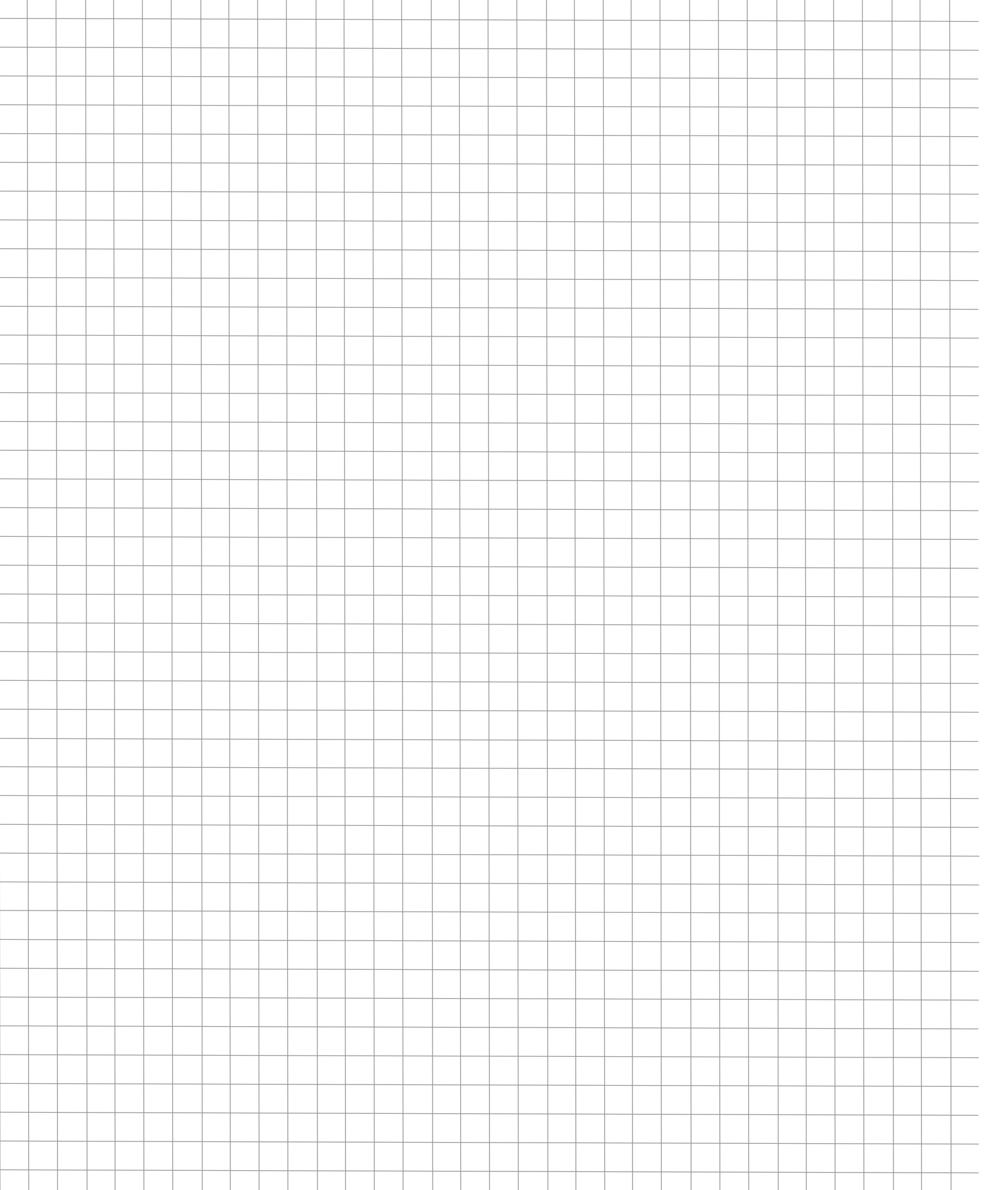

PHOTO FINISH RESULTS

Record your results of three Photo Finish computer races.

Before the race	Runner 1	Runner 2
Name		
Average speed		
Who had a head start?		
Race results	You said	Math said
Short race head start		
Time to finish short race		
Long race head start		
Time to finish long race		

Before the race	Runner 1	Runner 2
Name		
Average speed		
Who had a head start?		
Race results	You said	Math said
Short race head start		
Time to finish short race		
Long race head start		
Time to finish long race		

Before the race	Runner 1	Runner 2
Name		
Average speed		
Who had a head start?		
Race results	You said	Math said
Short race head start		
Time to finish short race		
Long race head start		
Time to finish long race		

BOAT SPEED

Four friends met at the park to run their boats. They decided to find out how fast each boat could go. They collected the distance and time data shown in the table.

Use the graphing program or the graph on page 31 to graph the speed of all four boats on one graph. Then answer the questions.

Boat	Δt (s)	d (m)
Mango	90	150
Perky	100	100
Whisper	30	150
Tornado	60	120

1. List the boats from fastest to slowest.

(1) _____ (2) _____ (3) _____ (4) _____

2. How far will each boat travel in 5 minutes?

(M) _____ (P) _____ (W) _____ (T) _____

3. (Extra credit) At what time should each boat start so all the boats will cross the finish line at 100 meters at the same time?

Boat	Starting time
Mango	
Perky	
Whisper	
Tornado	

Name _____

Period _____ Date _____

BOAT-SPEED GRAPHS

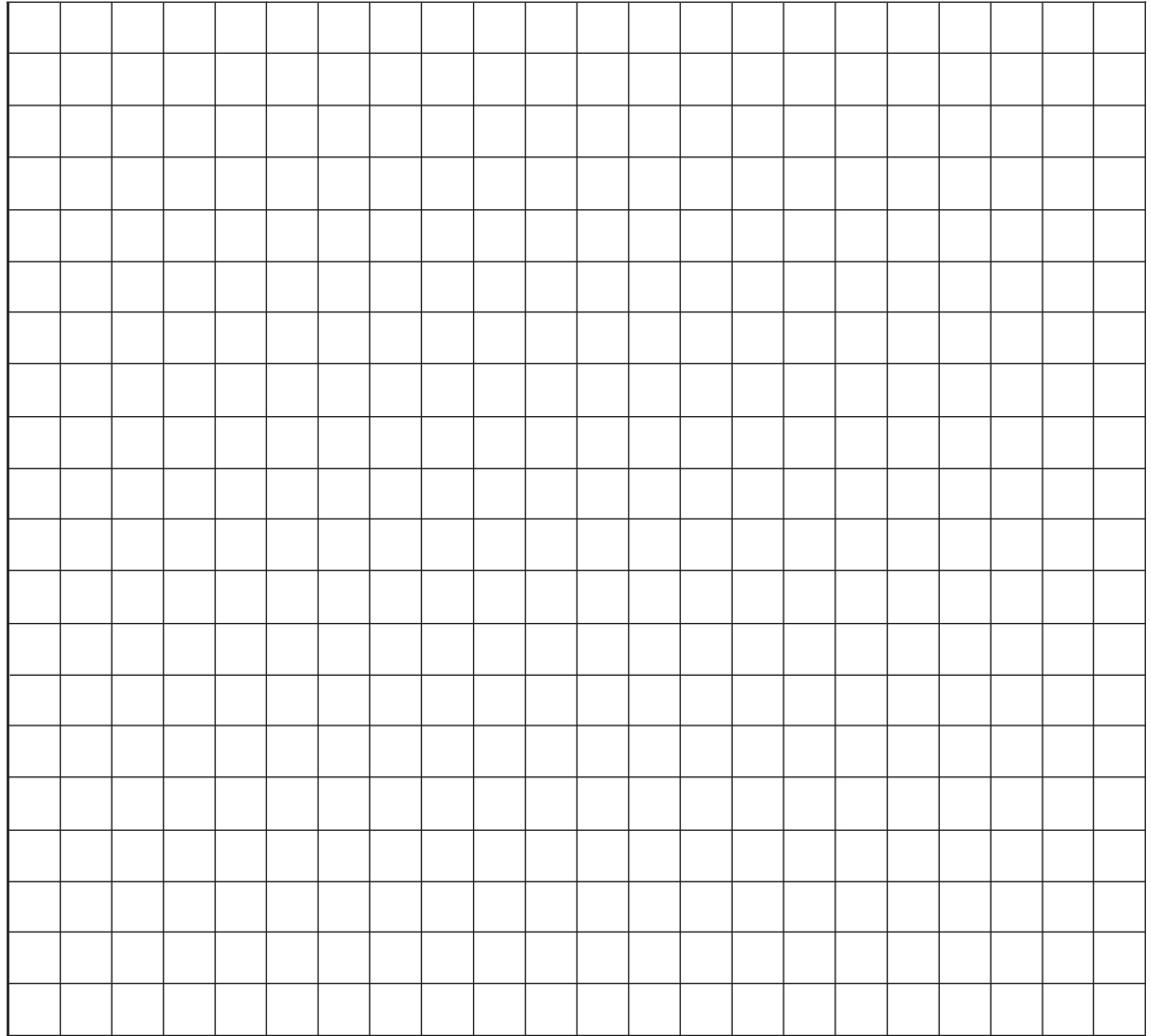

RESPONSE SHEET—COMPARING SPEEDS

Bert and Gaston each chose a snail that he thought might be the fastest. They each timed their snail and got the data on the right. They shared data and each reached a conclusion.

Snail	Distance	Time
Bert	12 cm	40 s
Gaston	15 cm	1 min.

Bert said,

I calculated the speed, and Gaston's snail is faster.

Gaston said,

Yes, mine is faster. The graph proves it. The line is longer.

Look at the boys' work and write comments below.

Bert's work

<p>Bert's snail</p> $v = \frac{d}{\Delta t} = \frac{12}{40} = 0.3 \text{ cm/s}$

<p>Gaston's snail</p> $v = \frac{d}{\Delta t} = \frac{15}{1} = 15 \text{ cm/s}$

Gaston's work

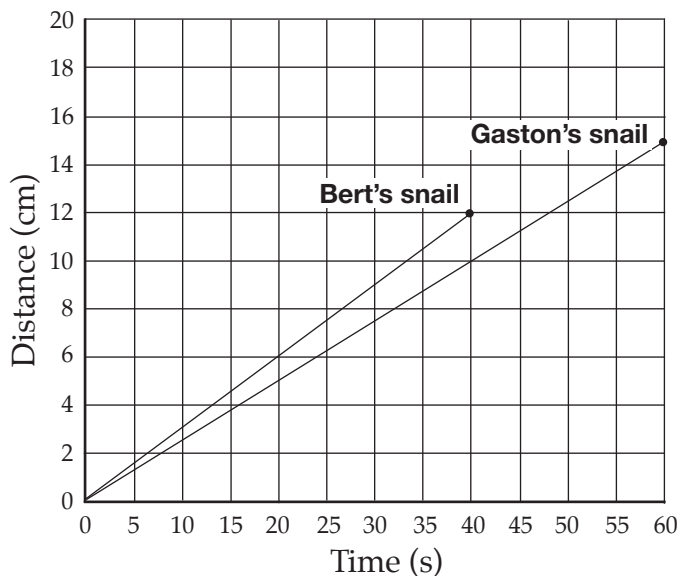

IDITAROD

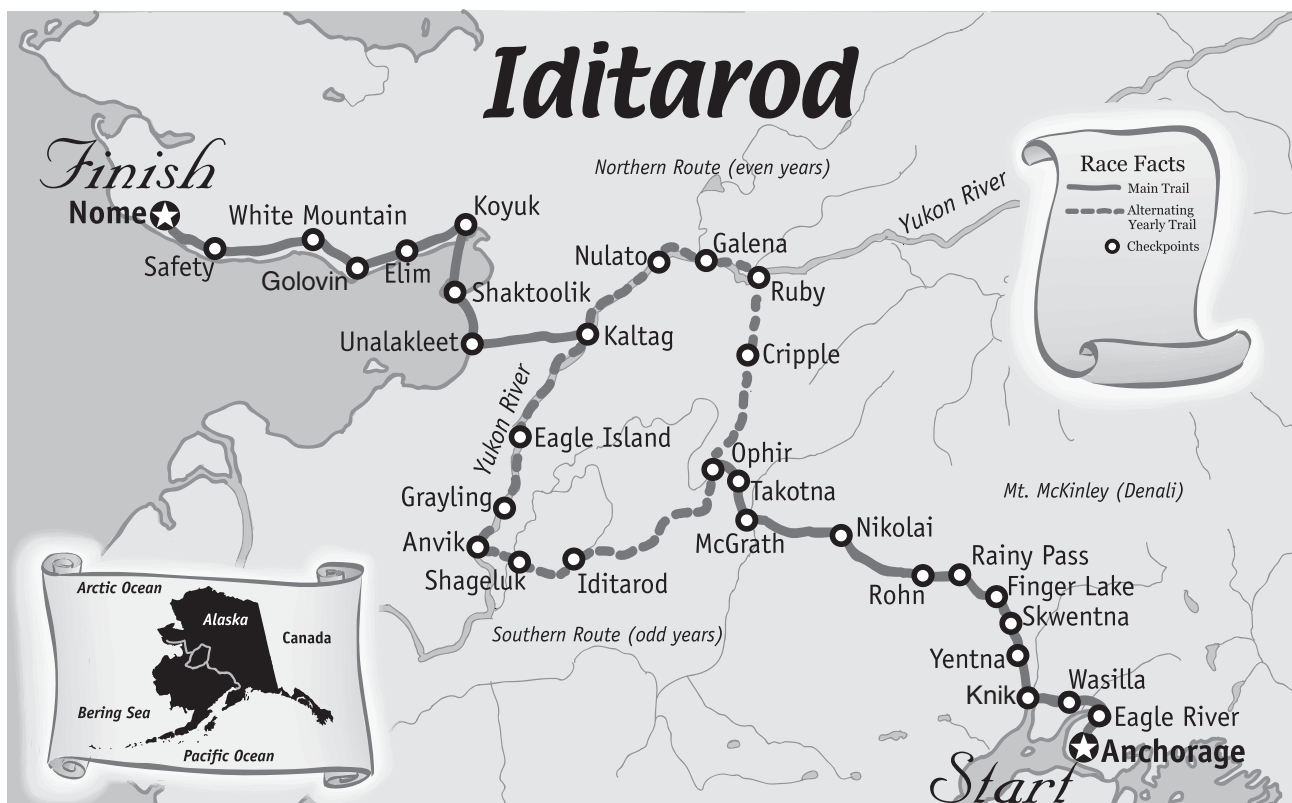

The Iditarod is a dog-sled race run each year in March. The mushers start in Anchorage, Alaska, and race to Nome. The distance is about 1800 kilometers (1125 miles).

In 1986 Susan Butcher won the race. Her record-breaking time was 11 days and 15 hours.

At each checkpoint the dogs were fed, rested, and examined by a vet. This took an average of 3 hours at each checkpoint. In addition, each team was required to make one 24-hour stop at one of the checkpoints, and two 8-hour stops at two other checkpoints.

1. What was the average speed of the dog team from start to finish?
2. What was the average speed of the dog team while it was actually on the trail?

SHOW TIME A

Sue Ellen and Josie went to the show Saturday afternoon. Josie's mom drove them the 5 kilometers to the show. The ride took 10 minutes.

The movie, *The Lizard Queen*, lasted 1 hour and 20 minutes. The girls then jogged home. It took them 40 minutes.

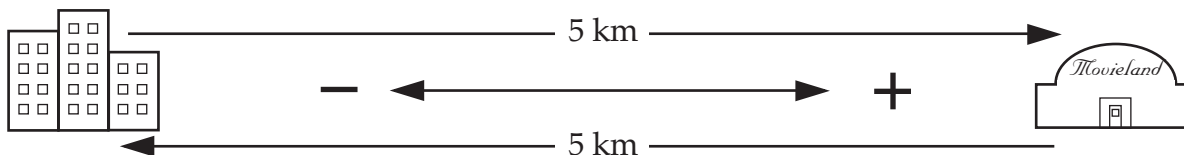

Leg	Time at end of leg t (min.)	Position at end of leg x (km)	Time interval during leg Δt (min.)	Displacement during leg Δx (km)	Total distance of travel d (km)
0	0	0			

a. Make a position graph that represents the girls' outing.

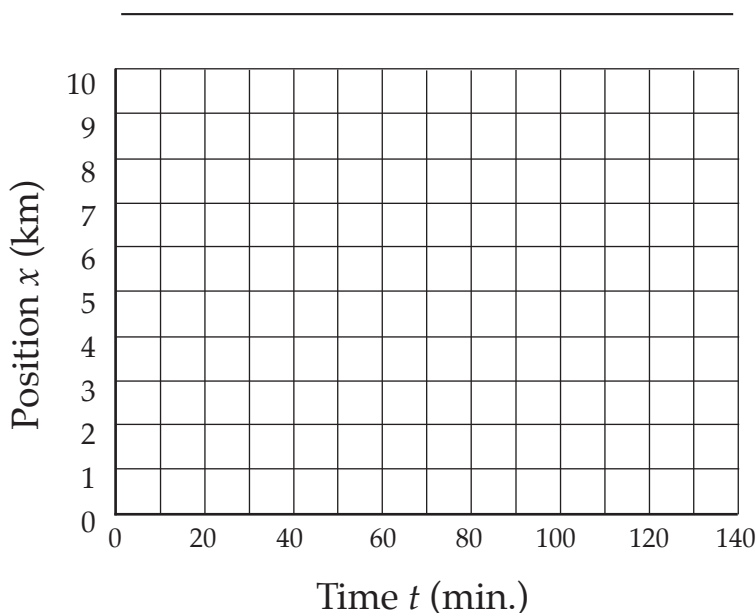

SHOW TIME B

- b. Make a distance graph that represents the girls' outing.

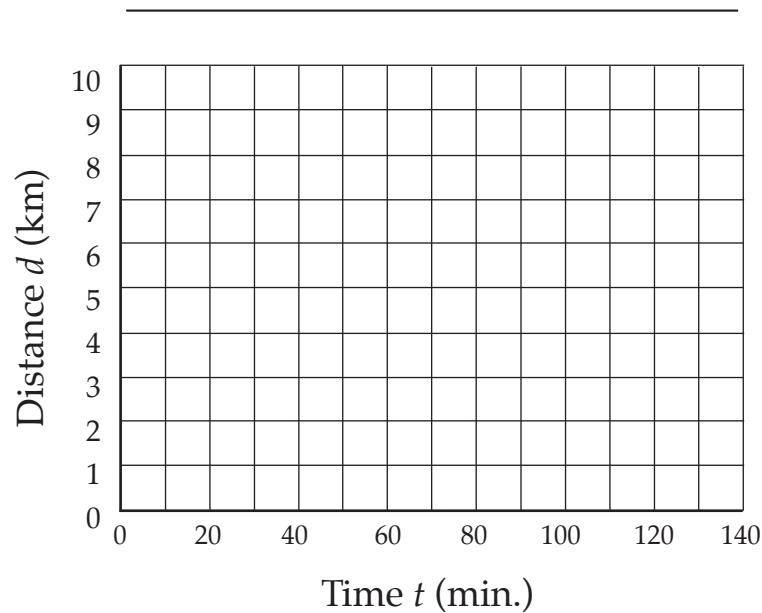

- c. What was the average speed for leg 1 of the trip? Show your math.
- d. What was the average speed for leg 2 of the trip? Show your math.
- e. What was the average speed for the whole outing? Show your math.

CLANCEY'S AFTERNOON A

It took Clancey 10 minutes to ride his skateboard 2 kilometers down the hill to Richie's house.

They played Claw on the computer for 20 minutes.

It took Clancey 20 minutes to walk back home up the hill.

Make a data table and two graphs to show Clancey's movement.

Leg	t (min.)	x (km)	Δt (min.)	Δx (km)	d (km)
0	0	0			0

Distance Graph

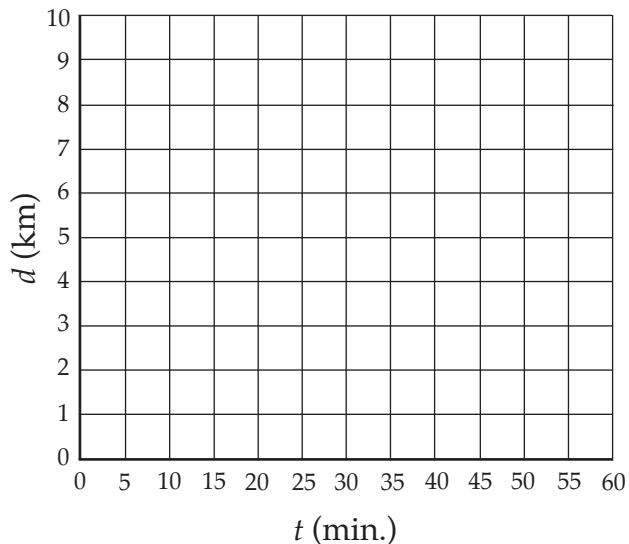

Position Graph

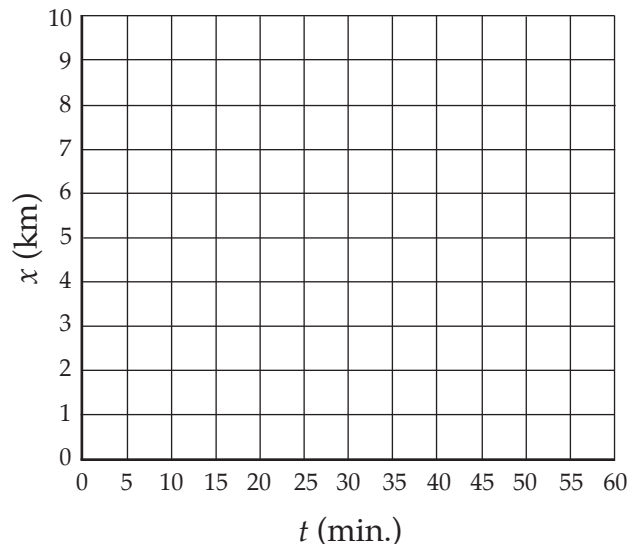

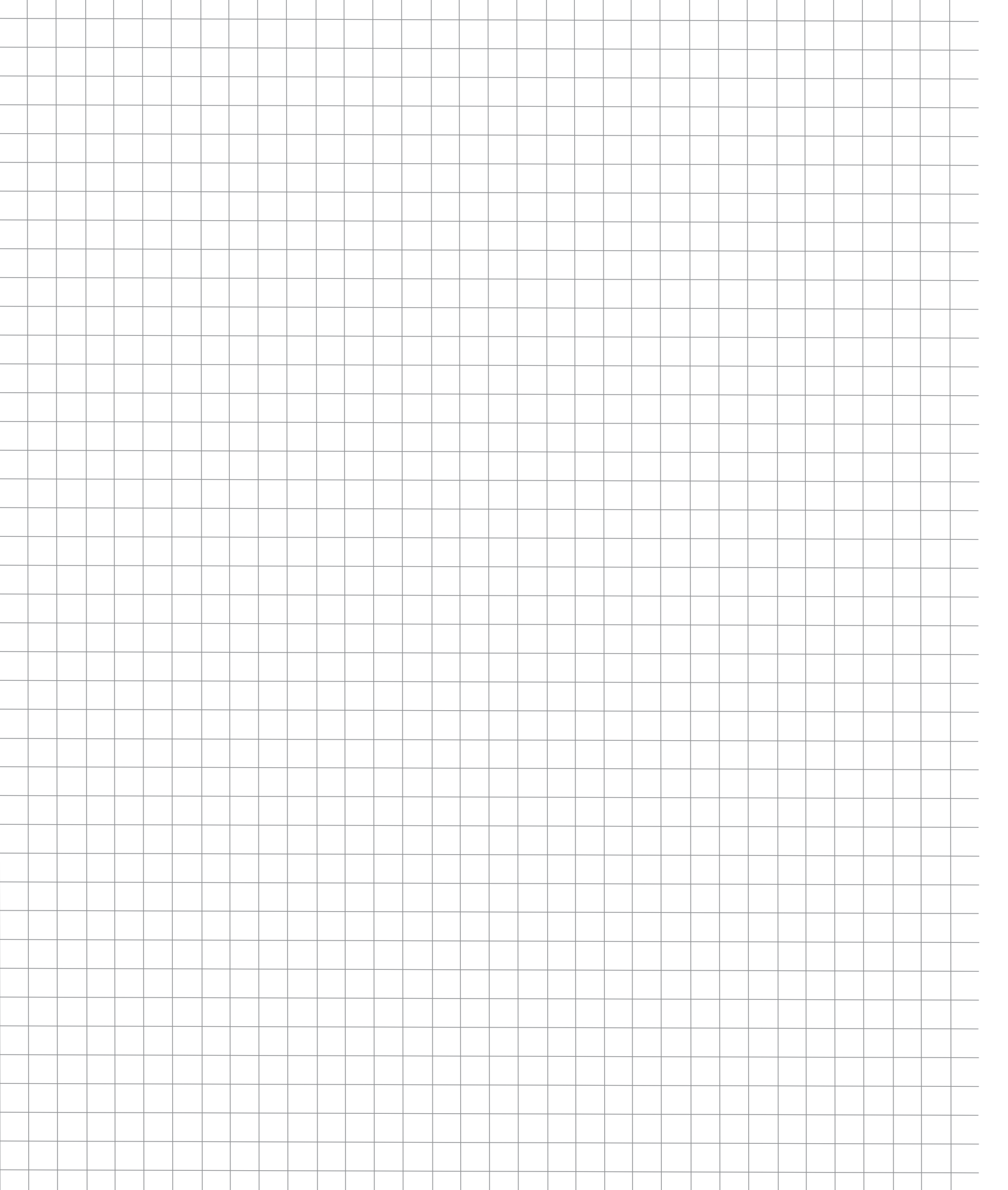

LEISURELY WALKS

Directions

- Walk together as a team. Two team members, **timer 1** and **timer 2**, will carry stopwatches.
- Study the instructions for the leisurely walks. Figure out how many legs are in each walk.
- Decide what timer 1 and timer 2 will time. Walk the walk and record data.

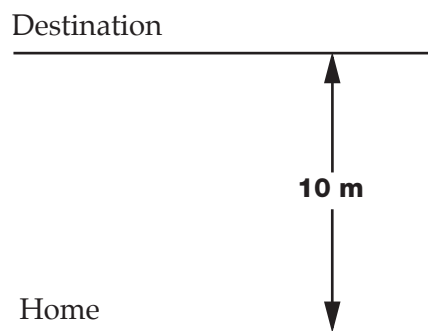

Leisurely Walk 1

Start at home.
Walk to the destination.
Immediately walk back home.

Leg	Δt (s)	Δx (m)	t (s)	x (m)	d (m)
0			0	0	0

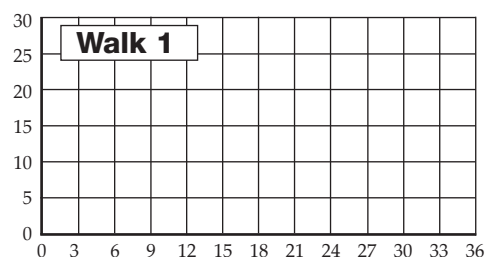

Leisurely Walk 2

Start at home.
Walk to the destination.
Look at view 15 seconds.
Walk back home.

Leg	Δt (s)	Δx (m)	t (s)	x (m)	d (m)

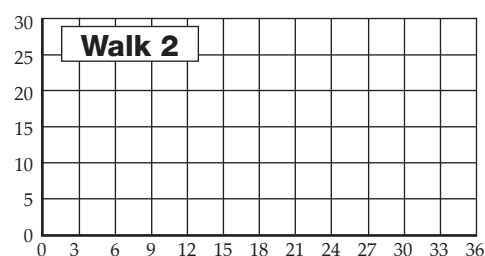

Leisurely Walk 3

Start at home.
Walk to the destination, turn, walk halfway home.
Stop and rest 10 seconds.
Complete the walk home.

Leg	Δt (s)	Δx (m)	t (s)	x (m)	d (m)

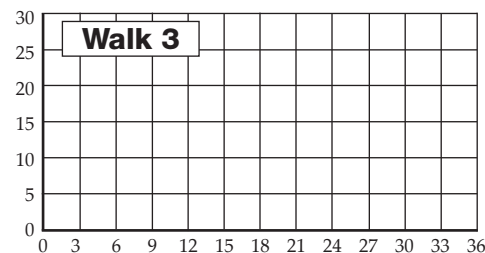

ROAD TRIP

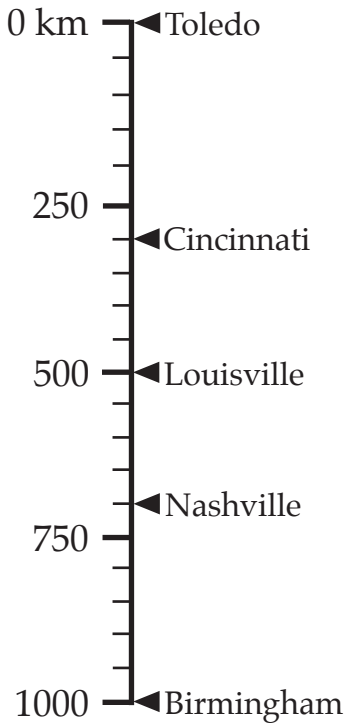

Hi Beth, this is Rita. I moved. I left Toledo at 9:00 a.m. on Saturday and drove 700 km. I arrived in Nashville at 7:00 p.m. and spent the night. I arrived in Birmingham Sunday afternoon at 5:00 p.m. I now know it is 1000 km from Toledo to Birmingham.

Actually, Beth, the trip didn't go exactly like that. Sunday morning at 9:00, I realized I left my credit card in Louisville when I stopped for gas. It took me 2 hours to drive back 200 km for it. I was so mad. Then I got on the road and made it to Birmingham.

Leg	Δt (h)	Δx (km)	t (h)	x (km)	d (km)

- Fill in your data table.
- Make a position graph of Rita's road trip.
- Make a distance graph of Rita's road trip.

ROAD-TRIP GRAPHS

.....

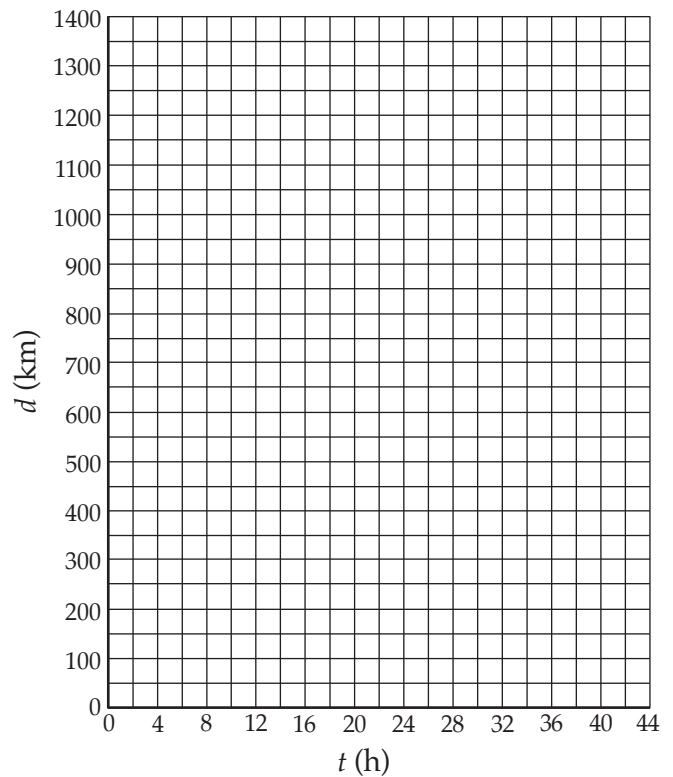
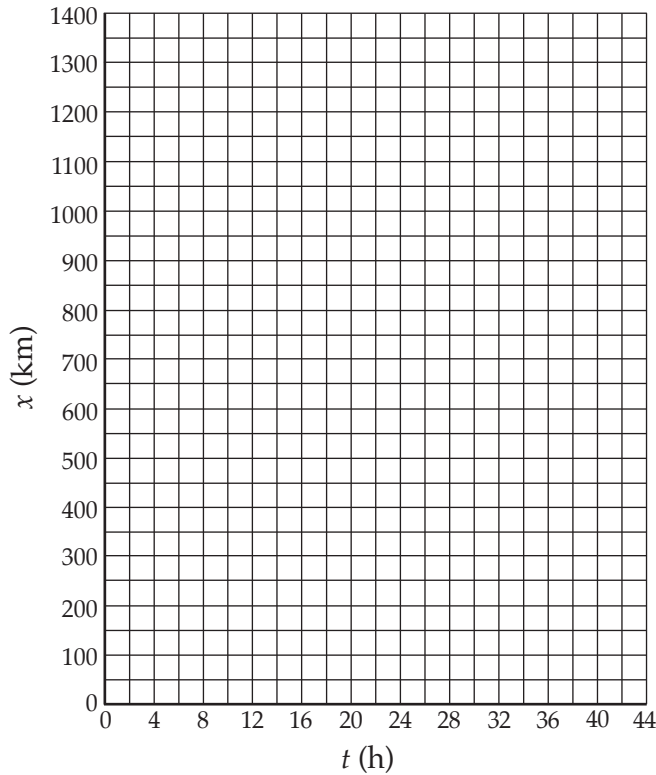

1. During which leg of the trip was Rita's speed the fastest?
2. What was Rita's average speed on her trip between Toledo and Birmingham?
3. What was Rita's average speed while she was actually driving on the road?

RESPONSE SHEET—REPRESENTING MOTION

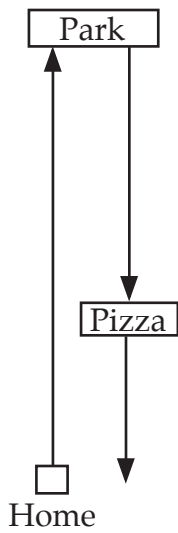

Marybeth and two friends went on a leisurely outing. They walked to the park 1500 meters from Marybeth’s house.

They watched the skateboarders awhile.

Then they took the bus toward home.

They got off at the pizza shop and shared a pineapple and ham pizza.

They walked the remaining 500 m home.

Marybeth and her two friends made motion graphs of the outing.

Which graph or graphs represent Marybeth’s movements during the outing?

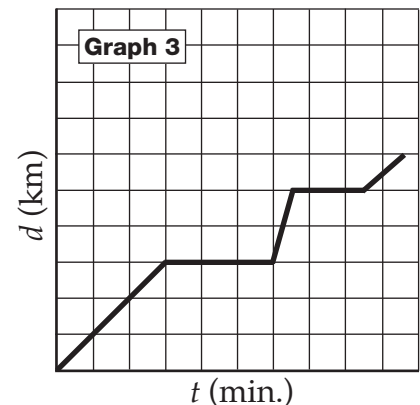
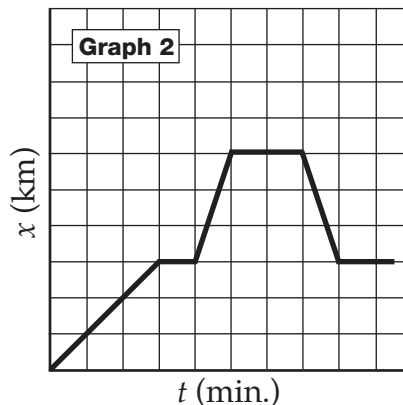
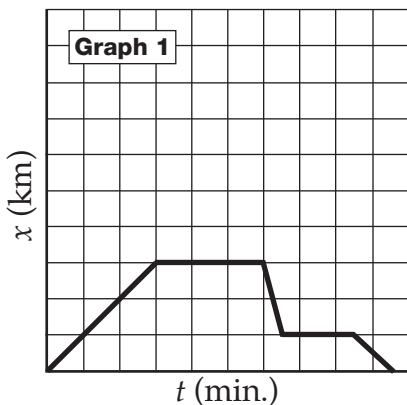

Explain which graph or graphs represent Marybeth’s movements.

GRAPH A MOTION EVENT

Make up a story to go with each of these motion graphs.

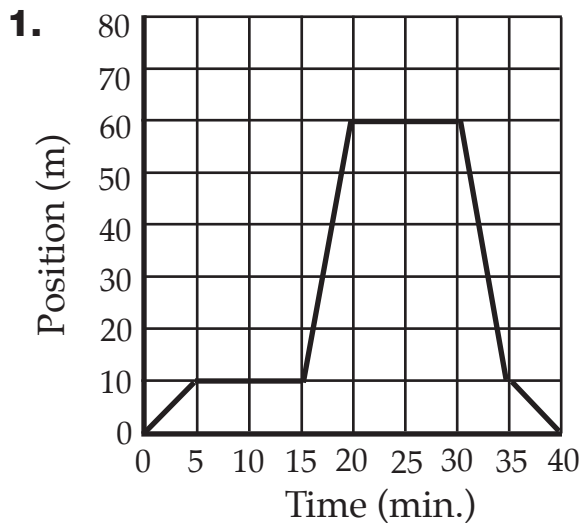

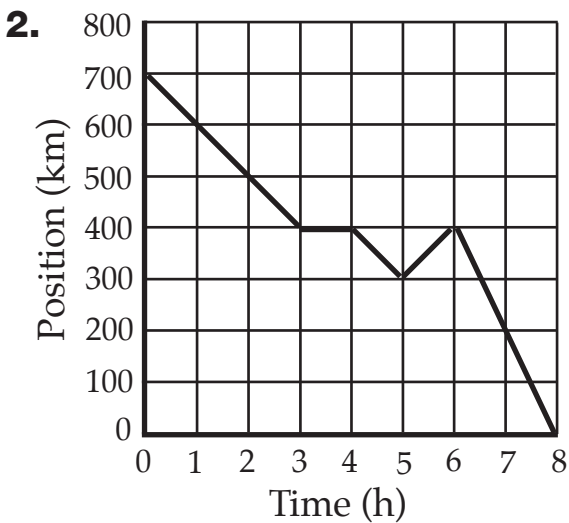

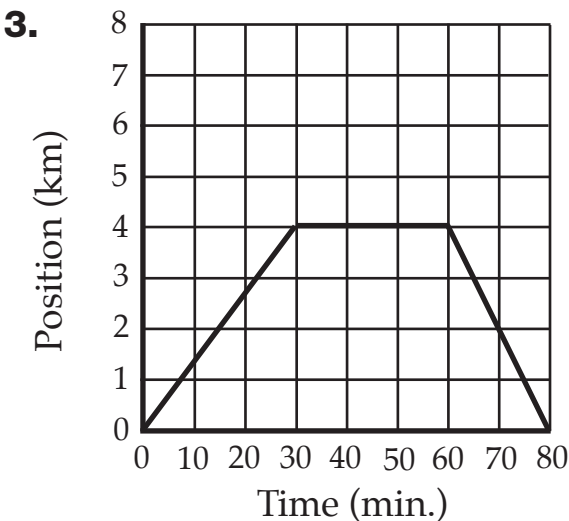

COMPARING TRACKS A

**Track 1
(long)**



**Track 2
(short)**

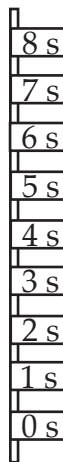

Walk the length of the long track and the short track.

Walk at a speed that will bring you to each number as it is called out. (The whole walk will take 8 seconds.)

The distance from the start (0 seconds) to each of the numbers is recorded in the data tables. Fill in the rest of both data tables.

Make position-versus-time graphs for both tracks.

1. Compare your positions (x) on the two tracks after 8 seconds.

2. Compare your velocities (\bar{v}) as you traveled on the two tracks.

3. Compare your change of velocity ($\Delta\bar{v}$) as you traveled the two tracks.

4. Discuss the difference between constant velocity and acceleration.

COMPARING TRACKS B

Track 1 (long)

t (s)	x (m)	Δx (m)	Δt (s)	\bar{v} (m/s)	$\Delta \bar{v}$ (m/s)	a (m/s ²)
0	0					
1	0.25					
2	1.0					
3	2.25					
4	4.0					
5	6.25					
6	9.0					
7	12.25					
8	16.0					

Track 2 (short)

t (s)	x (m)	Δx (m)	Δt (s)	\bar{v} (m/s)	$\Delta \bar{v}$ (m/s)	a (m/s ²)
0	0					
1	0.5					
2	1.0					
3	1.5					
4	2.0					
5	2.5					
6	3.0					
7	3.5					
8	4.0					

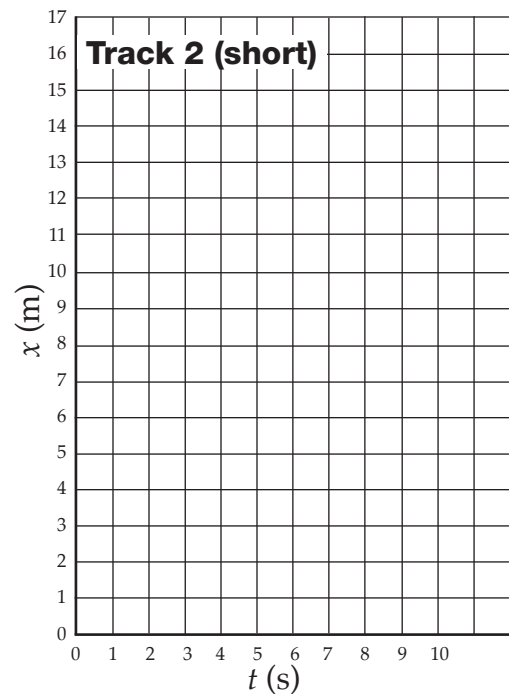
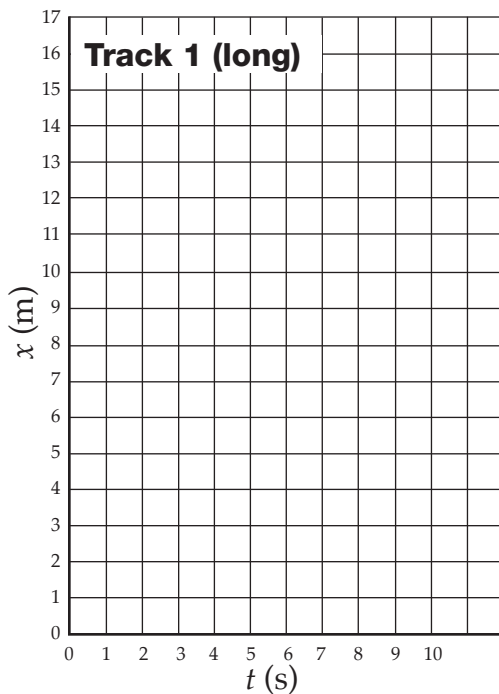

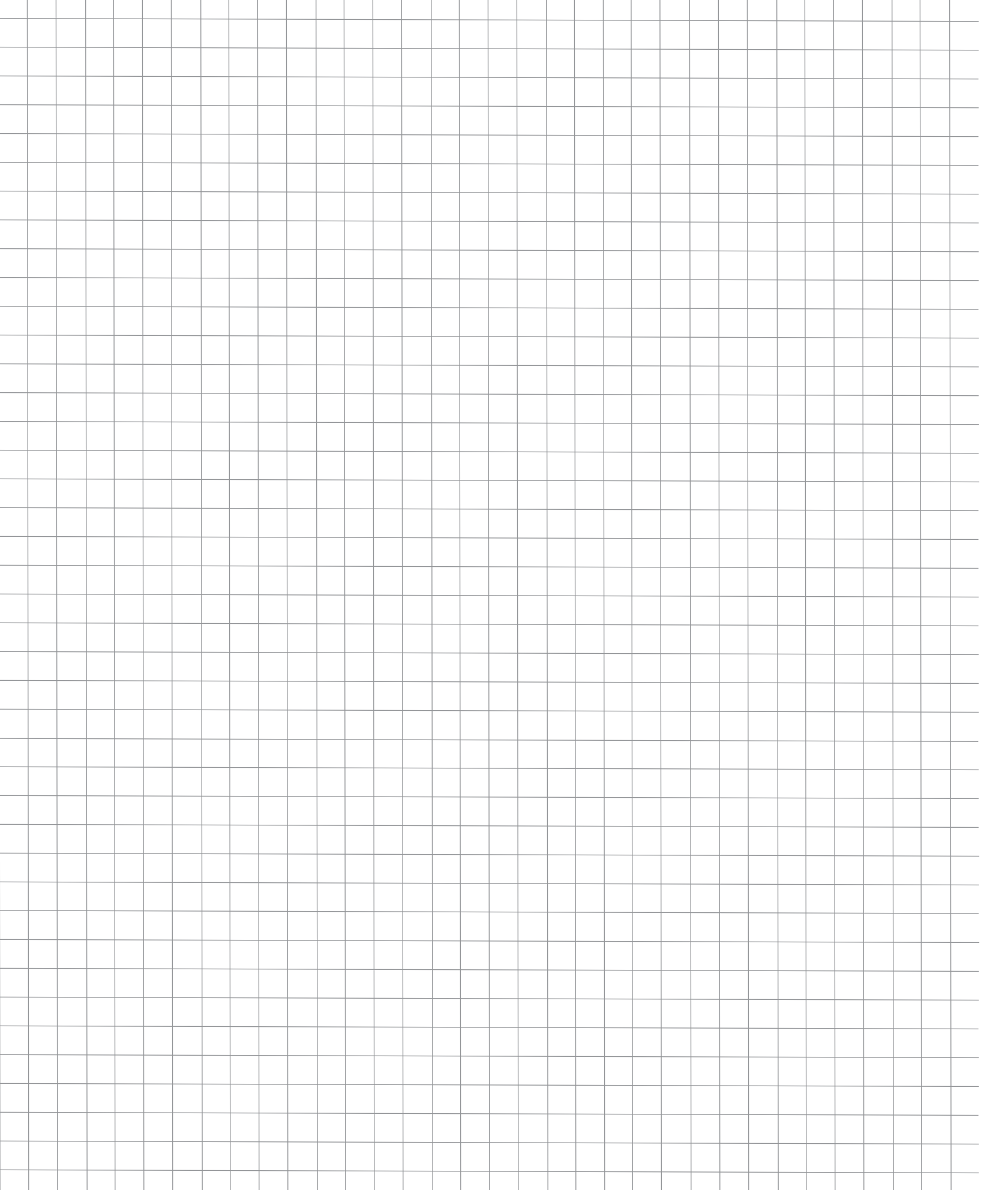

ROLLING DOTCAR

- How often does the Dotcar make a dot?
- Which slope did your Dotcar run down?

10 cm 15 cm 20 cm
- Use the dot record on your paper to fill in the first four columns on the data table.
- Calculate the velocity at the end of each half second.
- Calculate the average velocity for the run.
- Make a graph of position versus time.

Dot	t (s)	x (cm)	Δx (cm)	Δt (s)	\bar{v} (cm/s)
0	0	0			
1					
2					
3					
4					
5					
6					
7					
8					
9					
10					

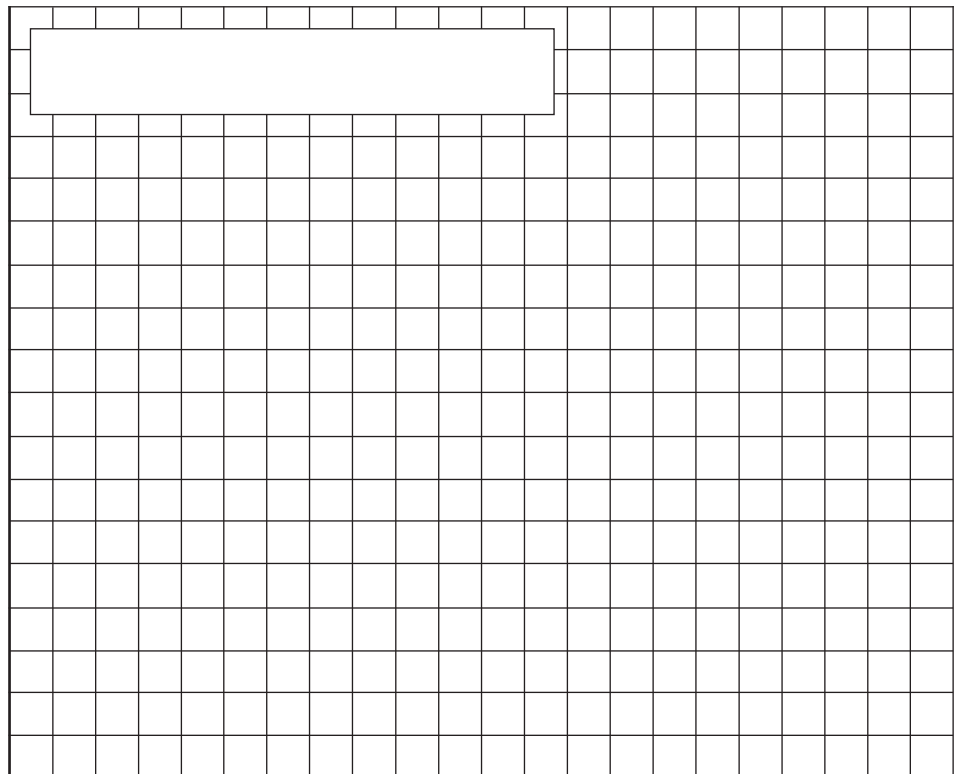

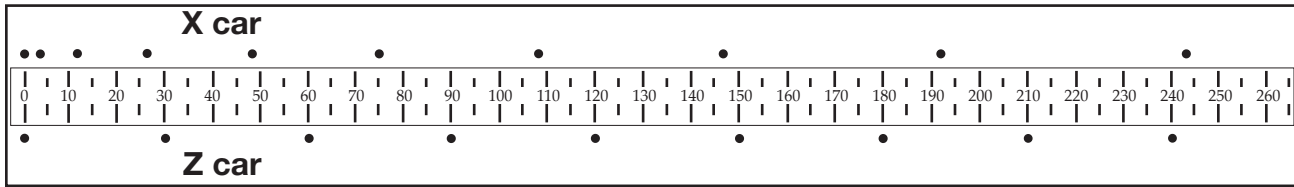
X CAR AND Z CAR A

Look at the Dotcar data for the X car and the Z car.

The Dotcars made a dot every 0.5 second.

The measuring tape is marked off in centimeters.

Answer the questions below.

- Which car was moving with positive acceleration? _____
- Which car was moving with negative acceleration? _____
- Which car was moving with constant velocity? _____
- Which car traveled with the greater average velocity for the first 4 seconds? (Show your math.)
- Which car was going faster at the end of 4 seconds? (Show your math.)
- At what time will the two cars be the same distance from the start, and how far will they be? (Hint: Make a graph.)

Name _____

Period _____ Date _____

X CAR AND Z CAR B

.....

X car

Dot	t (s)	x (cm)	Δx (cm)	Δt (s)	\bar{v} (cm/s)

Z car

Dot	t (s)	x (cm)	Δx (cm)	Δt (s)	\bar{v} (cm/s)

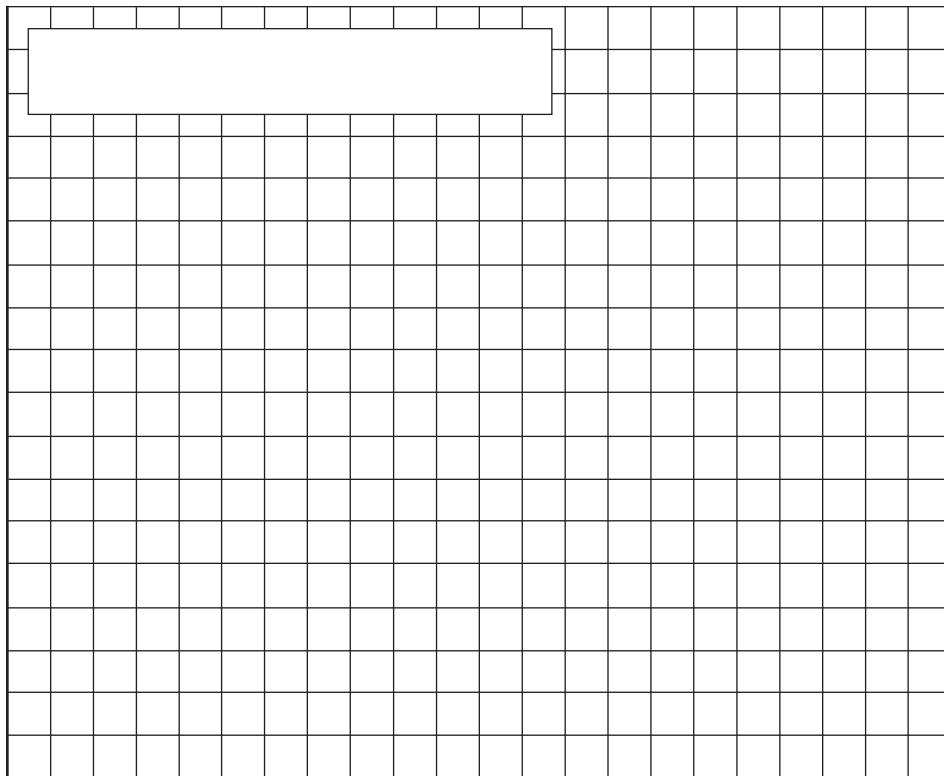

DOTMAKER A**Select the movie group called Bike Walk.**

- Choose the movie called **Bike Walk 1**.
- Play the movie and watch the action. Then press Rewind.

Select walker from the “choose an object” menu.

- Choose a **reference point** on the yellow-shirted walker, like his nose.
- Use the cross hairs to place a dot on the reference point.
- Use the Step button to advance the action five frames (five clicks).
- Place another dot on the reference point.
- Continue placing dots on the reference point every five frames.

Select bicyclist from the “choose an object” menu.

- Click Rewind. Click the Step button until the bike enters the scene.
- Choose a reference point on the bike and place a dot.
- Place a dot on the bike’s reference point every five frames.

1. Which moving object, the walker or the bicyclist, traveled faster? (Click Hide Movie to see the dots clearly.) _____

2. How do you know which object was faster?

3. Click the Graph Data button, then the Automatic button to see graphs of the two motions. Are the objects traveling at constant velocity or accelerating?

4. What additional information is provided by the graphs?

DOTMAKER B**Compare additional movies.**

You can compare the movement of up to four moving objects in a movie group.

The objects can be in the same movie or in different movies.

You can place dots close together (every frame) or far apart (every ten or more frames).

Comparison 1

I selected these movies: _____

I placed dots every _____ frames.

This is what I learned about these moving objects.

Comparison 2

I selected these movies: _____

I placed dots every _____ frames.

This is what I learned about these moving objects.

Comparison 3

I selected these movies: _____

I placed dots every _____ frames.

This is what I learned about these moving objects.

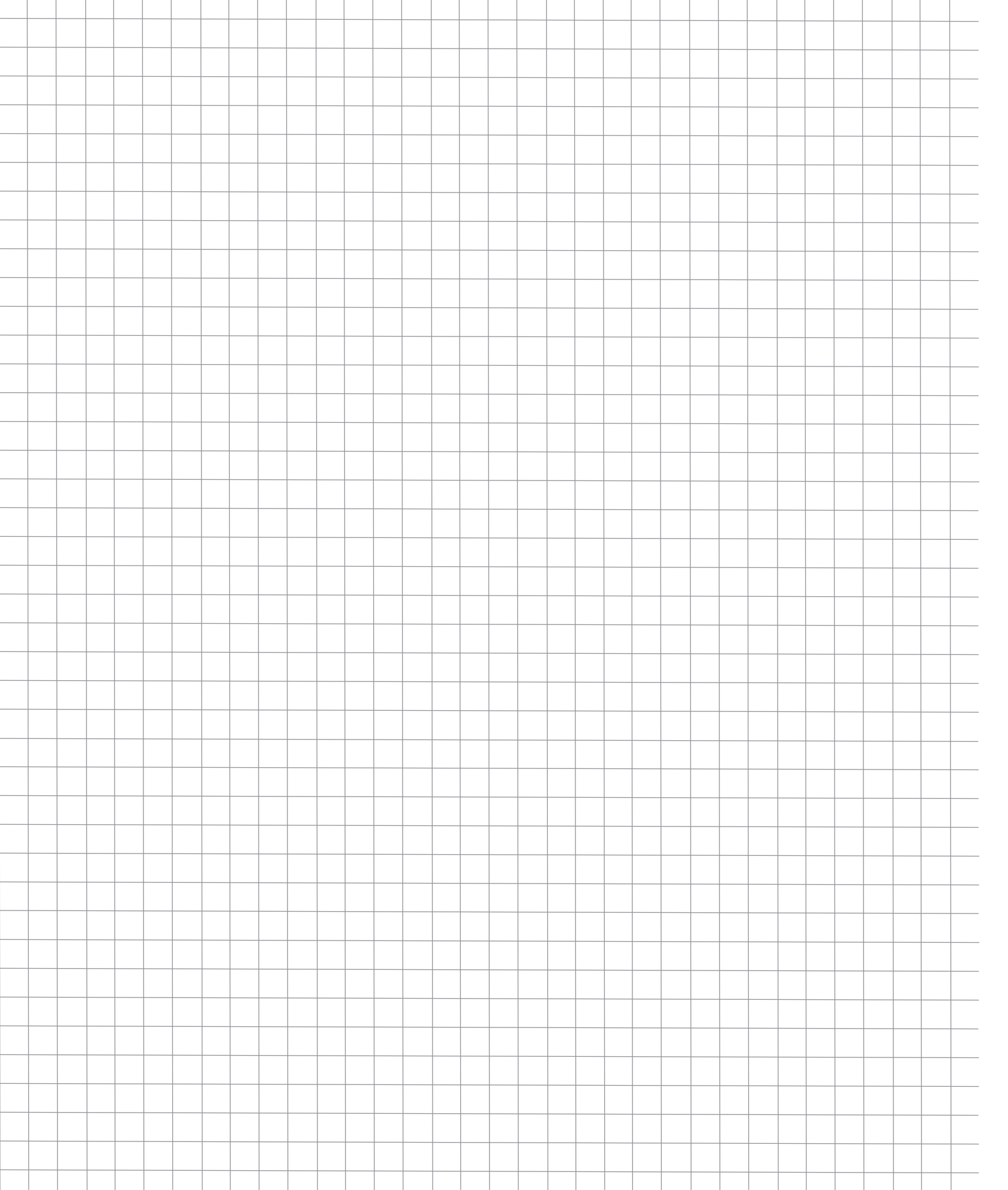

RESPONSE SHEET—ACCELERATION

Quinn and Mattie watched two skiers go by on a trail. They noticed that both skiers pushed one ski pole into the snow exactly once per second. They studied the trail after the skiers went past.

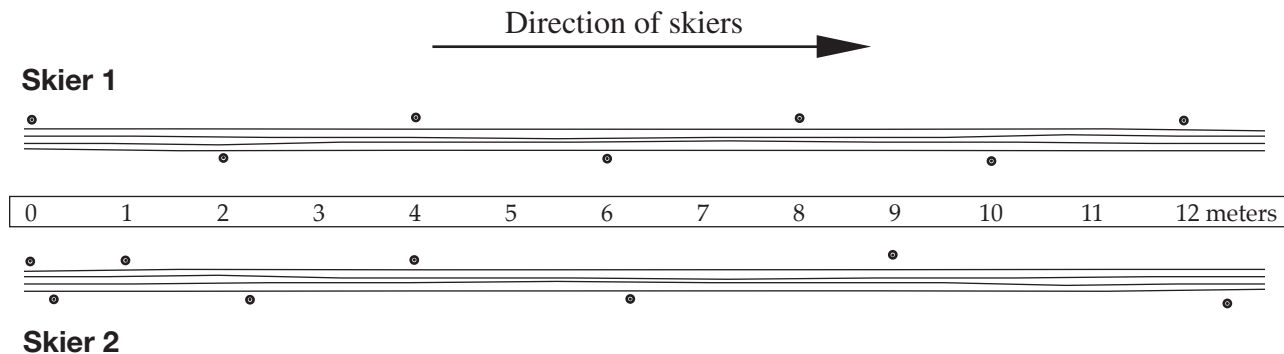

Quinn said,

It looks to me like skier 1 was accelerating. He was going fast all the way.

Mattie said,

It looks to me like skier 2 was accelerating. He was going slower at the start.

Discuss Quinn's and Mattie's ideas about the skiers.

ACCELERATION PRACTICE A

1. A robot rolled down a ramp and across the floor.
 - a. Circle the position where the robot was going fastest.

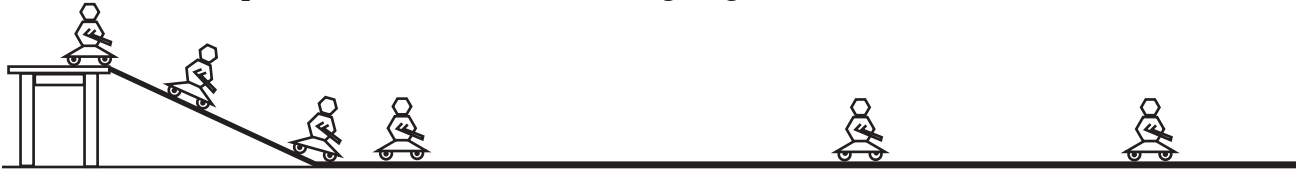

- b. Why do you think it was going fastest at that point?

2. Mr. Bell's students had two Dotcars that made one dot every second. The students made these two runs. Answer the questions below.

Dotcar 1



Dotcar 2

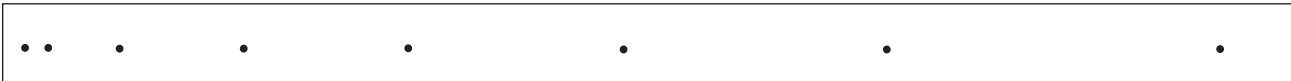

- a. Which Dotcar accelerated in the first 3 seconds? _____
- b. Which Dotcar accelerated in the last 3 seconds? _____
- c. Which Dotcar had gone farther after 6 seconds? _____
- d. Which Dotcar was going faster after 6 seconds? _____
- e. How do you know it was going faster after 6 seconds?

ACCELERATION PRACTICE B

3. Some students observed the motion of a toy car and a toy bus. The data records, however, were incomplete. Graph the car and the bus motion and answer the questions.

Car

t (s)	x (cm)
0	0
1	0.5
2	2
3	4.5
4	
5	12.5
6	18
7	
8	32
9	40.5
10	50

Bus

t (s)	x (cm)
0	0
1	
2	8
3	12
4	
5	
6	24
7	28
8	
9	36
10	40

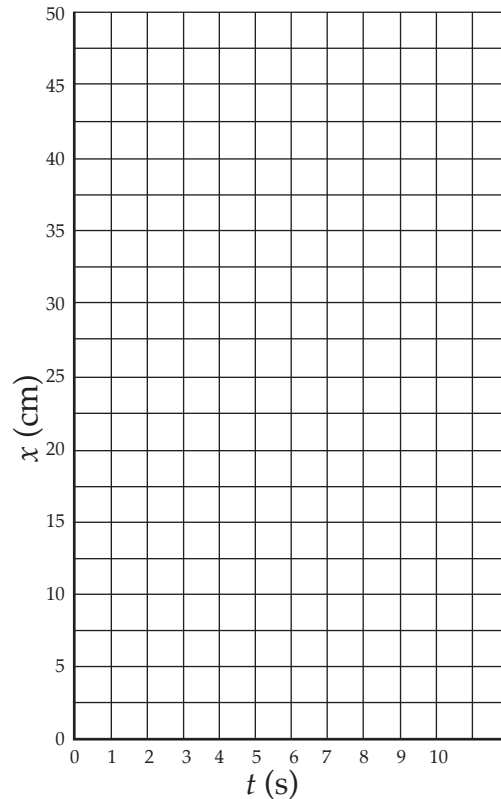

- a. Was the car traveling at a constant velocity or accelerating? How do you know?

- b. Was the bus traveling at a constant velocity or accelerating? How do you know?

- c. When were the two vehicles going the same velocity?

Name _____

Period _____ Date _____

CARS AND LOADS B

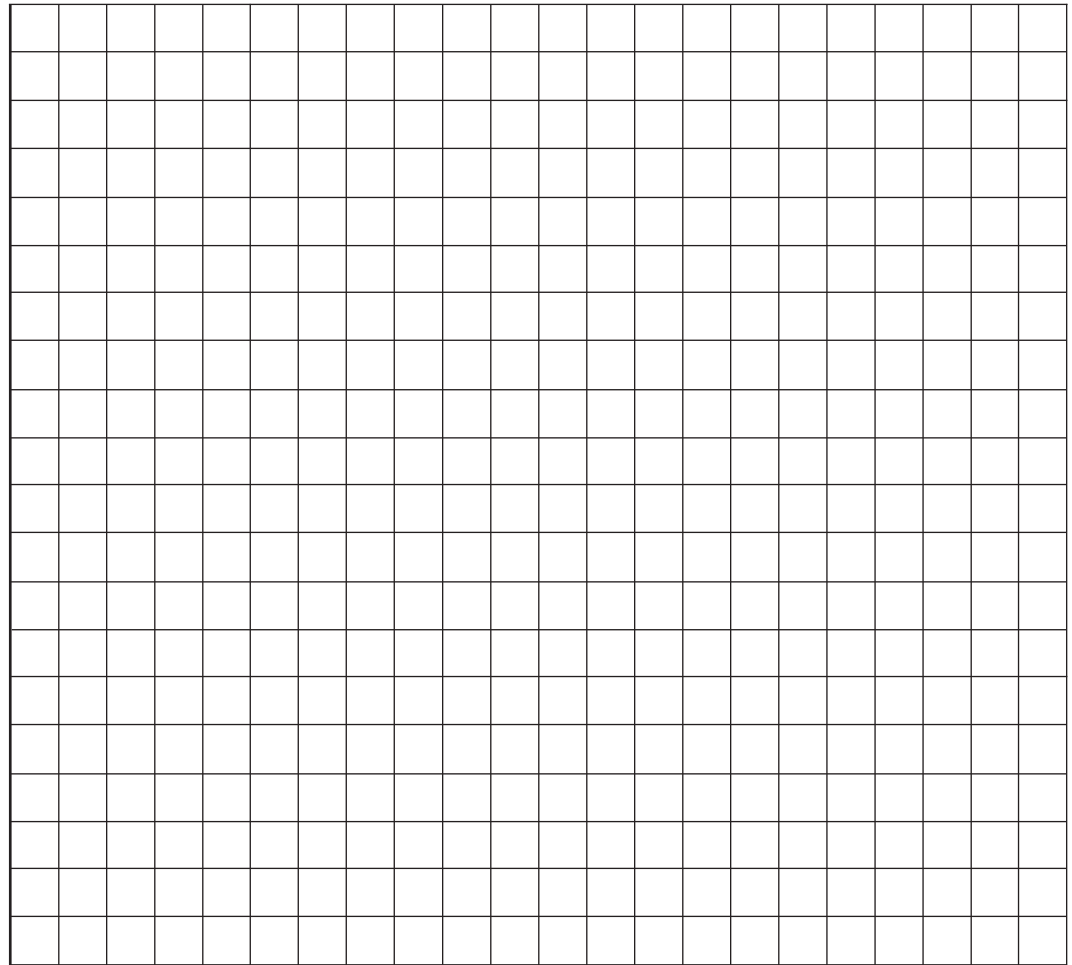

Part 3: What did you find out about rolling Dotcars from this experiment?

PUSHER ASSEMBLY

Materials

- | | |
|----------------------------------|----------------|
| 1 Vial and cap with hole | 1 Paper slider |
| 1 Wood dowel, drilled and marked | 1 Scissors |
| 1 Rubber band | |

Assembly

- a. Cut the rubber band on an angle to make a rubber strand with pointed ends.

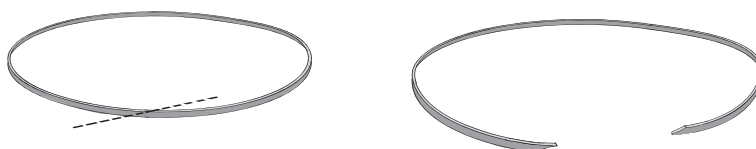

- b. Push the rubber strand through the hole in the dowel and tie a knot at each end. The knots should be close to the ends of the strand.

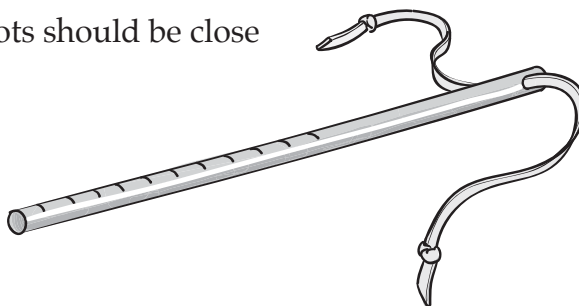

- c. Push the dowel through the hole in the vial from the bottom. Push the ends of the rubber strand into the notches in the lip of the vial. The knots should be inside the vial.

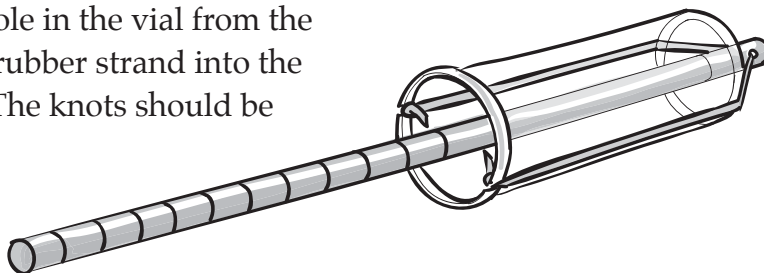

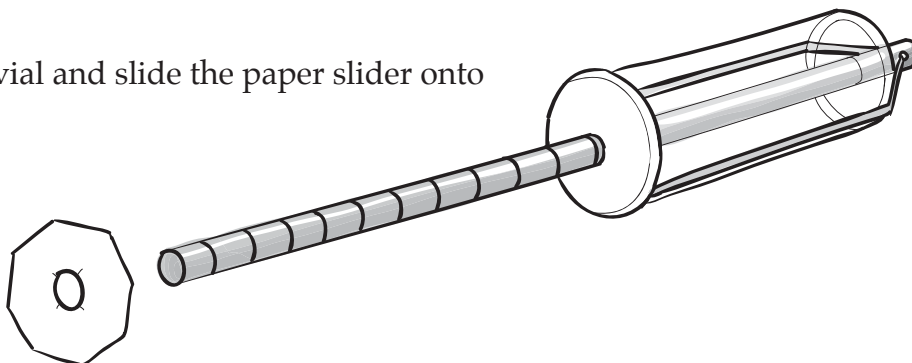

- d. Snap the cap on the vial and slide the paper slider onto the dowel.





PUSHES AND PULLS A

Part 1: Pushing and pulling different masses

You will need one pusher and three masses.

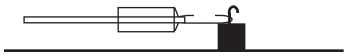
1. How much force does it take to push	Three trials	Average
1 mass? 	_____	_____
3 masses? 	_____	_____
Predict the force required to push 2 masses.	_____	_____
What force was needed to push 2 masses?	_____	_____

2. How much force does it take to pull	Three trials	Average
1 mass? 	_____	_____
3 masses? 	_____	_____
Predict the force required to pull 2 masses.	_____	_____
What force was needed to pull 2 masses?	_____	_____

3. What is the relationship between the mass of an object and the force needed to slide it across a surface?

Part 2: Push against push

You will need two pushers.

1. What happens when pusher A and pusher B **both push** with a 4-N force on each other?

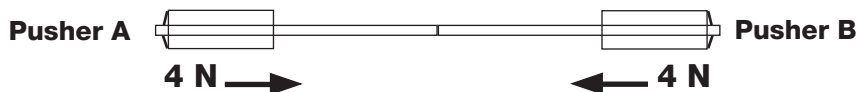

PUSHES AND PULLS B

2. Hold pusher A **still** and **push** with a 4-N force with pusher B.



- a. What happened to pusher A?

- b. Explain why that happened.

Part 3: Forces on cars

You will need two pushers and one Dotcar.

1. What happens when pusher A **pushes** with a 2-N force on one side of the car and pusher B **pushes** with a 3-N force on the other side of the car?



2. What happens when pusher A **pulls** with a 6-N force on one side of the car and pusher B **pulls** with a 6-N force on the opposite side of a car?



PUSHES AND PULLS C

.....

3. Apply a 2-N **pull** with pusher A and a 2-N **push** with pusher B on the car.



- a. Explain what happens to the car when the forces are applied.

- b. How could you use one pusher to produce the same result?

4. What causes cars to move?

FORCE AND SLEDS

Set up a pulley and load system. Use it to answer the following questions.

- Use a spring scale to lift a load attached to a string that runs over a pulley. How much force is needed to lift the load? _____
- How much force is needed to lift the load when you have a sled between the end of the string and the scale? _____
- How much force is needed to lift the load with 1, 2, 3, and 4 masses on the sled?

Masses on sled	Force (N) to lift the load	Change of force (N)	Force (N) to lift the load using rollers	Change of force (N)
0				
1				
2				
3				
4				

- How much force is needed to lift the load when straw rollers are placed **under** the sled and 1, 2, 3, and 4 masses are placed **on** the sled?

- Friction exerts a force to oppose movement. What did you find out about friction?

FORCES ON CARTS A

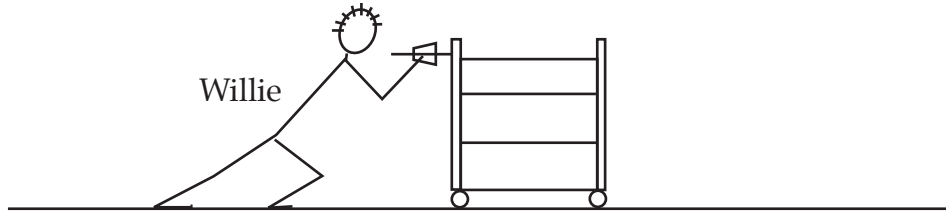

1. Willie's class found that the cart will move when pushed with 50 newtons of force. When Willie pushed on the cart with 10 newtons of force, why didn't the cart move?

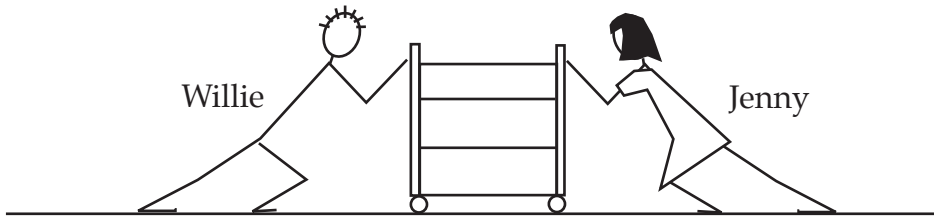

2. Willie pushed on the cart with 500 newtons of force. Jenny pushed on the other side of the cart. The cart didn't move. How much force did Jenny apply? _____

Why do you think so?

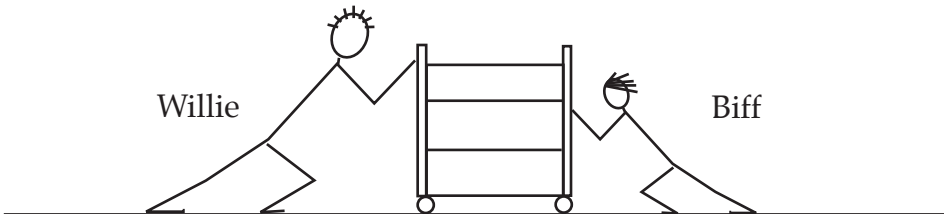

3. Willie and Biff pushed on the cart and it didn't move. Biff pushed with 400 newtons of force. How much force did Willie apply?

FORCES ON CARTS B

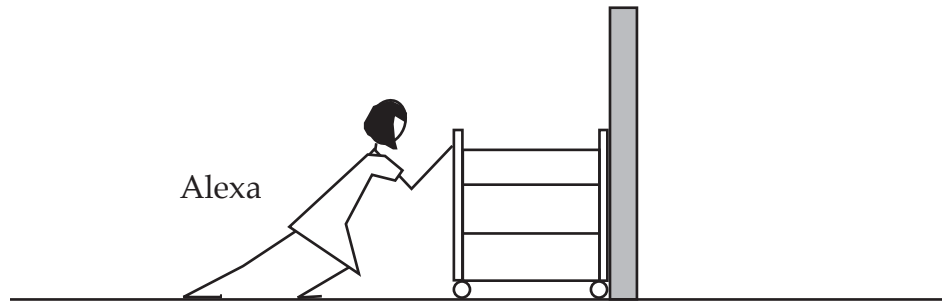

4. Alexa pushed on a cart against the wall with 500 newtons of force. The cart didn't move. How do you explain what happened?

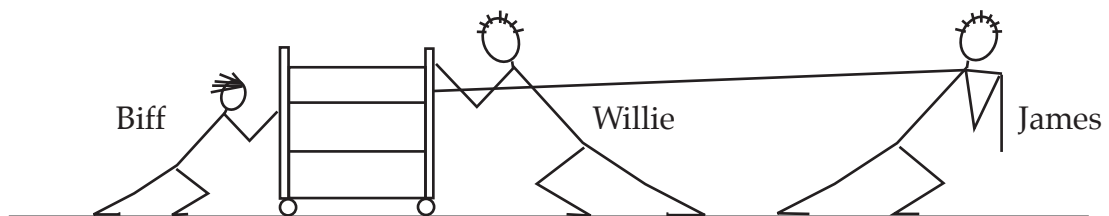

5. Willie pushed on the cart with 1000 newtons of force. James pulled on a rope attached to the cart with 500 newtons of force. Biff pushed on the cart with 400 newtons. What will happen to the cart and why?

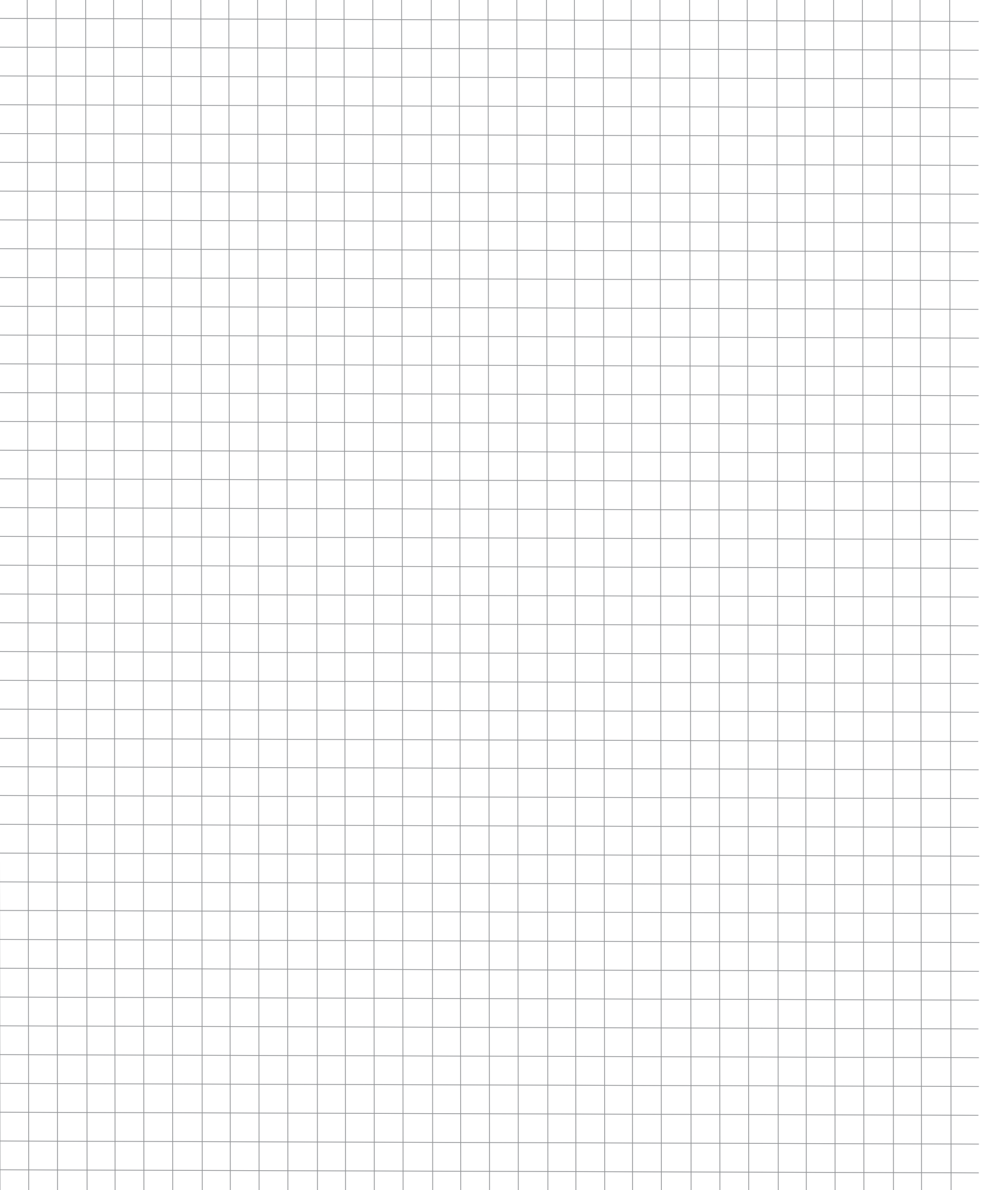

FORCE BENCH EXPERIMENTS

The force gizmo can push or pull, depending on which button you push.

- push
 pull

You can decide when to start applying force and when to end the force by putting numbers in the Start and End boxes. When the start time is set to zero, the force starts as soon as you press the Exert button.

start	2
end	4

You can select the number of masses to load on the sled and whether the sled is sliding on a surface with friction or without it.

Force Bench problems

1. Make the sled go slowly for 2 seconds and then speed up with both gizmos pushing.

Left force		start	
		end	

Right force		start	
		end	

2. Make the sled go slowly for 2 seconds and then speed up with one gizmo pushing and one pulling.

Left force		start	
		end	

Right force		start	
		end	

3. Make the sled move off-screen to the right and then return to its starting position.

Left force		start	
		end	

Right force		start	
		end	

4. Make the sled move to the right slowly, pause 3 seconds, and then move off-screen left.

Left force		start	
		end	

Right force		start	
		end	

5. Put three masses on the sled and make the surface frictionless. Exert a force of 5 newtons on the left side of the sled for 2 seconds. Explain what you observe.

Name _____

Period _____ Date _____

LIFE-RAFT DROP B

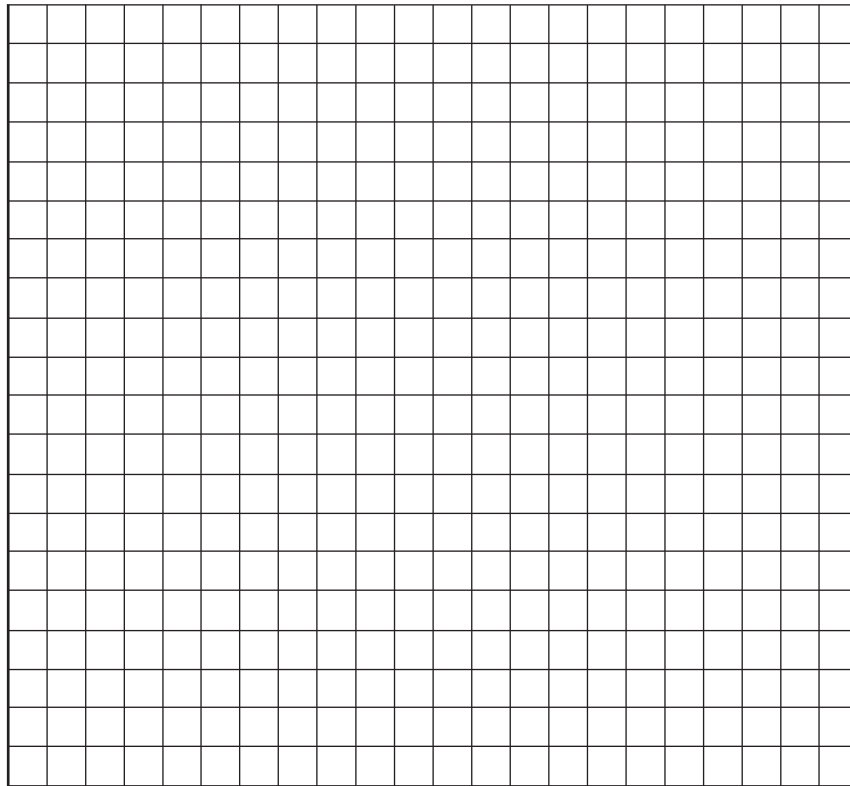

1. Did the raft fall at a constant velocity or did it accelerate? How do you know?

2. What was the acceleration of the raft as it fell?

3. What caused the raft to stop accelerating?

CALCULATING VELOCITY AND DISTANCE

If you know

- an object's **acceleration**, and
- **how long** it has been accelerating,

you can calculate its **velocity** and **distance (or position)**.

1. The equation for calculating velocity (\bar{v}) is $\bar{v} = a \times t$,
where a is acceleration and t is time.

2. The equation for calculating total distance traveled (d) is $d = \frac{a \times t^2}{2}$, or $\frac{1}{2} a t^2$
where a is acceleration and t is time.

Example. A soccer ball was dropped from a window in a tall building. It hit the ground in exactly 3 seconds. How fast was it going when it hit the ground? How far did it fall?

We know the ball is accelerating at 10 m/s^2 (the acceleration due to gravity). Using the velocity equation (1) and a time of 3 seconds, we can make the following calculation:

$$\bar{v} = a \times t = 10 \text{ m/s}^2 \times 3 \text{ s} = 30 \text{ m/s, the velocity at 3 s, the time it hit the ground.}$$

Using the distance equation (2), we can calculate how high the window was.

$$d = \frac{a \times t^2}{2} = \frac{10 \text{ m/s}^2 \times (3 \text{ s})^2}{2} = \frac{10 \text{ m/s}^2 \times 9 \text{ s}^2}{2} = \frac{90 \text{ m}}{2} = 45 \text{ m}$$

VELOCITY AND DISTANCE PRACTICE
.....

1. A jet airplane taxied down the runway at a constant acceleration of 3 m/s^2 . It lifted off 30 seconds after starting its taxi. How fast was the plane going when it left the ground, and how far down the runway had it gone? (To convert meters per second into kilometers per hour: $\text{km/h} = \text{m/s} \times 3.6$.)
2. A bowling ball started rolling down a long, gentle slope at constant acceleration of 10 cm/s^2 . How fast would it be going after 2 minutes and how far down the slope would it be?
3. It takes a parachute 4 seconds to open. What is the lowest platform a sky diver could safely jump from? How fast would she be going just as the chute opens?
4. A soccer player kicked a ball straight up in the air. It hit the ground exactly 5 seconds after the ball left the kicker's foot. How high did the ball go and how fast was it traveling when it hit the ground? (Hint: The upward and downward parts of the ball's flight take exactly the same amount of time.)
5. Jack made an air trolley powered by a balloon. The trolley can accelerate at a constant acceleration of 2 m/s^2 for 2 seconds. How far does the trolley go before the air runs out? If Jack got a larger balloon that could accelerate the balloon twice as long, how far would the trolley go before running out of air?
6. How long would it take a free-falling sky diver to reach a velocity of 180 km/h ? How far would he fall before reaching that velocity?

Name _____

Period _____ Date _____

RESPONSE SHEET—GRAVITY

Donna said,

I think a falling apple would accelerate more slowly on the Moon than on Earth because the force of gravity is less.

Anita said,

I think a falling apple would accelerate faster on the Moon than on Earth because there is no air on the Moon.

Who do you think has a better idea? Explain your reasons.

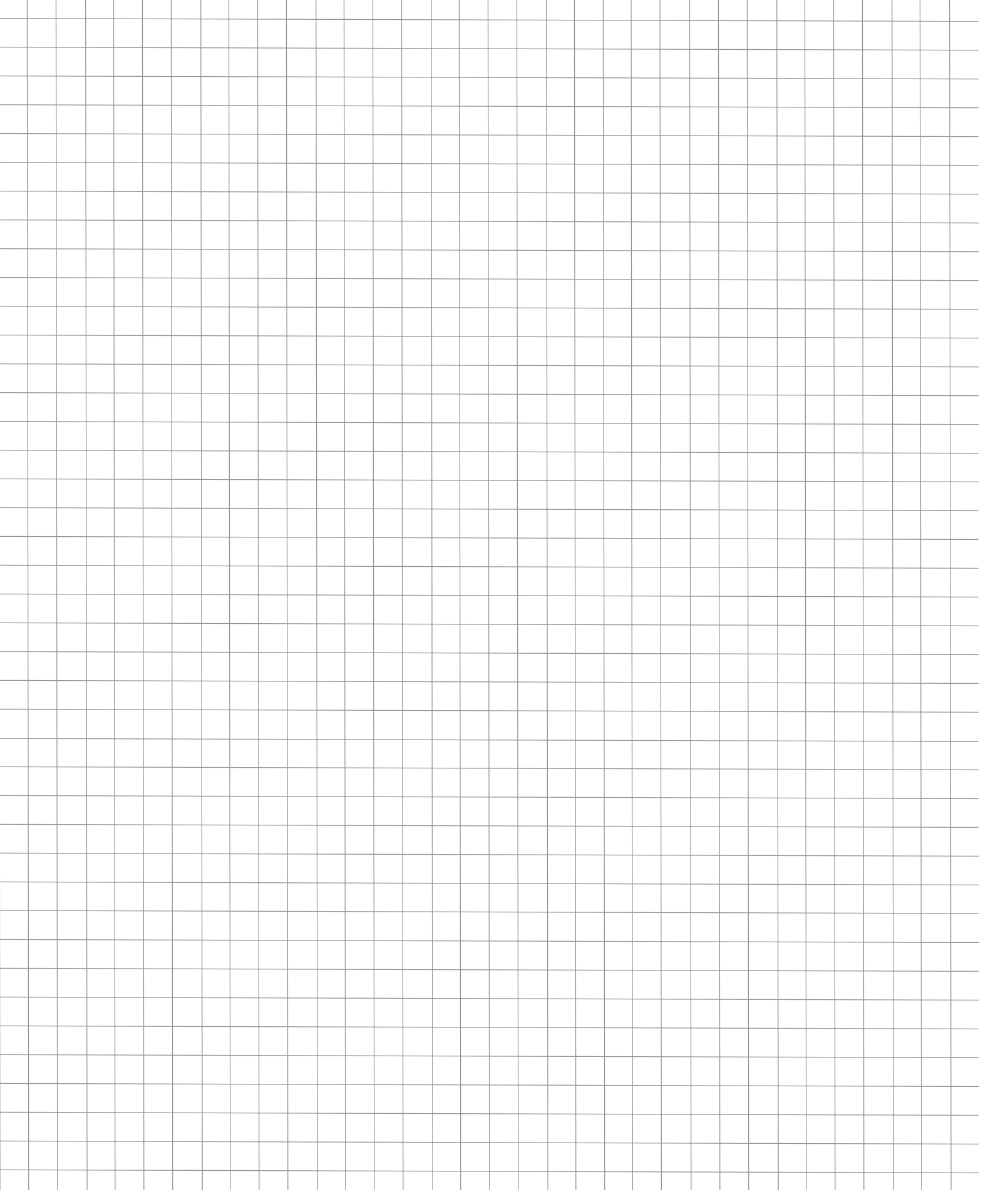

TESTING GALILEO'S RULE

- a. Look at your Dotcar data. Divide it into four to seven equal time intervals. Note: Time intervals on steep ramps might be two- or three-tenths of a second long. Time intervals on low ramps might be five-tenths of a second. Write your time interval here.

Time interval _____

- b. Fill in the x column on the table. This is **Dotcar's position compared to the start position ($x = 0$)**, not change of position during each time interval.
- c. Calculate the Δx column on the table. This *is* the change of position during each time interval.
- d. Fill in the theoretical change of position column by multiplying your first Δx by the number in the column.
- e. Compare your experimental Δx values to the theoretical Δx values.

Time interval	Position x (cm)	Change of position Δx (cm)	Theoretical change of position Δx (cm)
1			$1 \times =$
2			$3 \times =$
3			$5 \times =$
4			$7 \times =$
5			$9 \times =$
6			$11 \times =$
7			$13 \times =$

RUNAWAY FLOAT A

Materials

- 1 Float (Dotcar)
- 1 Ramp and surface
 - Ramp prop
- 1 Pusher
- 2 Washer bundles
- 1 Meter tape
 - Masking tape
 - Sweaters or towels

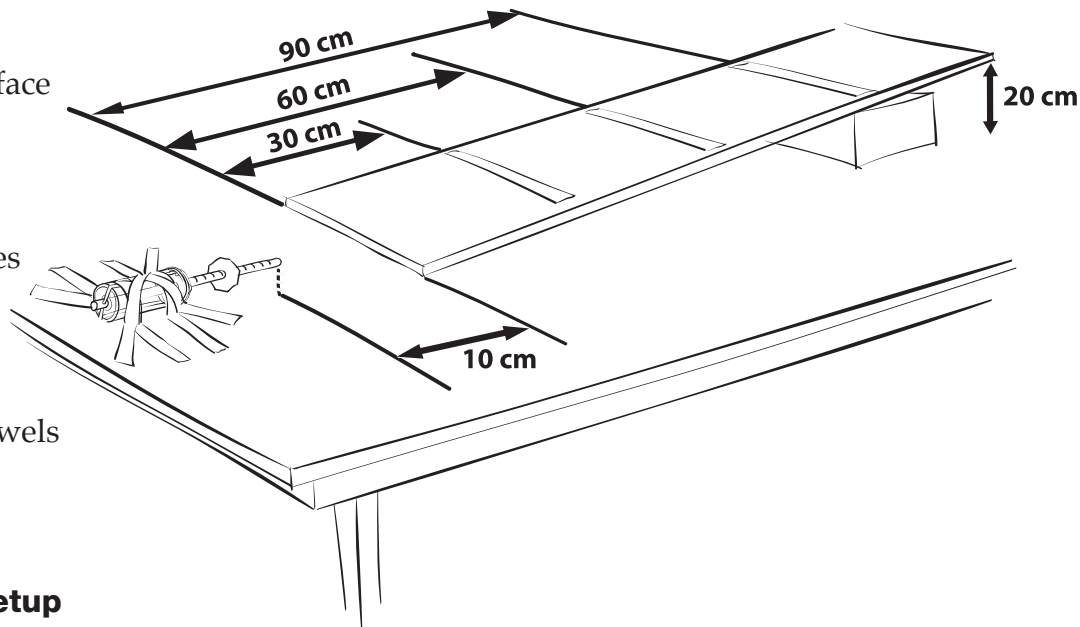

Experimental Setup

- a. Set up a ramp with one end raised 20 cm. Attach the plastic ramp surface to the board. Tape down the bottom of the ramp.
- b. Tape the pusher to the table so that the end of the dowel is 10 cm from the end of the ramp. Make sure the tape doesn't touch the rubber band on the pusher.
- c. Use tape to mark 30 cm, 60 cm, and 90 cm from the bottom edge of the ramp.
- d. Use sweaters or towels to set up a soft wall around the pusher to capture stray floats.

Procedure

- a. Zero your pusher.
- b. Position the float facing downhill with its front bumper right on the 30-cm line.
- c. Aim for the pusher dowel and release the float.
- d. Record the force data.
- e. Repeat the process with the float at 60 cm and 90 cm.
- f. Repeat steps a–e with one washer bundle on board.
- g. Repeat steps a–e with two washer bundles on board.

RUNAWAY FLOAT B

1. Which floats were traveling with the greatest velocity at the time of impact? How do you know?

2. Which floats were most massive at the time of impact? How do you know?

Float	Distance (cm)	Force to stop the float (N)
NO added mass	40 cm	
	70 cm	
	100 cm	
ONE added mass	40 cm	
	70 cm	
	100 cm	
TWO added masses	40 cm	
	70 cm	
	100 cm	

3. What effect does velocity just before impact have on the force needed to stop the float?

4. What effect does mass have on the force needed to stop the float?

5. Could a 1000-kg car stop a 4000-kg dump truck if they crashed head-on? Explain.

FLOAT MOMENTUM A

- Set up a ramp with one end elevated 20 centimeters (cm). Tape a pusher 10 cm from the bottom of the ramp.
- Plan to collect data on your electronic Dotcar for one float condition—one mass and one distance from starting point to the pusher.
- Run your float into the pusher. Write your position data in the x column. Fill in the other columns of the table to determine the velocity of your float at the time of impact.

Float mass _____

Distance from starting point to pusher _____

t (s)	x (cm)	Δx (cm)	\bar{v} (cm/s)	$\Delta \bar{v}$ (cm/s)	a (cm/s ²)
0.0					
0.1					
0.2					
0.3					
0.4					
0.5					
0.6					
0.7					
0.8					
0.9					
1.0					
1.1					
1.2					
1.3					
1.4					
1.5					
1.6					

FLOAT MOMENTUM B

Float	Distance from pusher (cm)	Mass (g)	Velocity at impact (cm/s)	Momentum (p) (g-cm/s)
NO added mass	100	~130		
	70	~130		
	40	~130		
ONE added mass	100	~190		
	70	~190		
	40	~190		
TWO added masses	100	~250		
	70	~250		
	40	~250		

1. What is the relationship between an object's mass and its momentum? How do you know?

2. What is the relationship between an object's velocity and its momentum. How do you know?

3. In a head-on collision, how fast would a 1000-kg car have to be going to stop the motion of a 4000-kg truck traveling at 20 km/h?

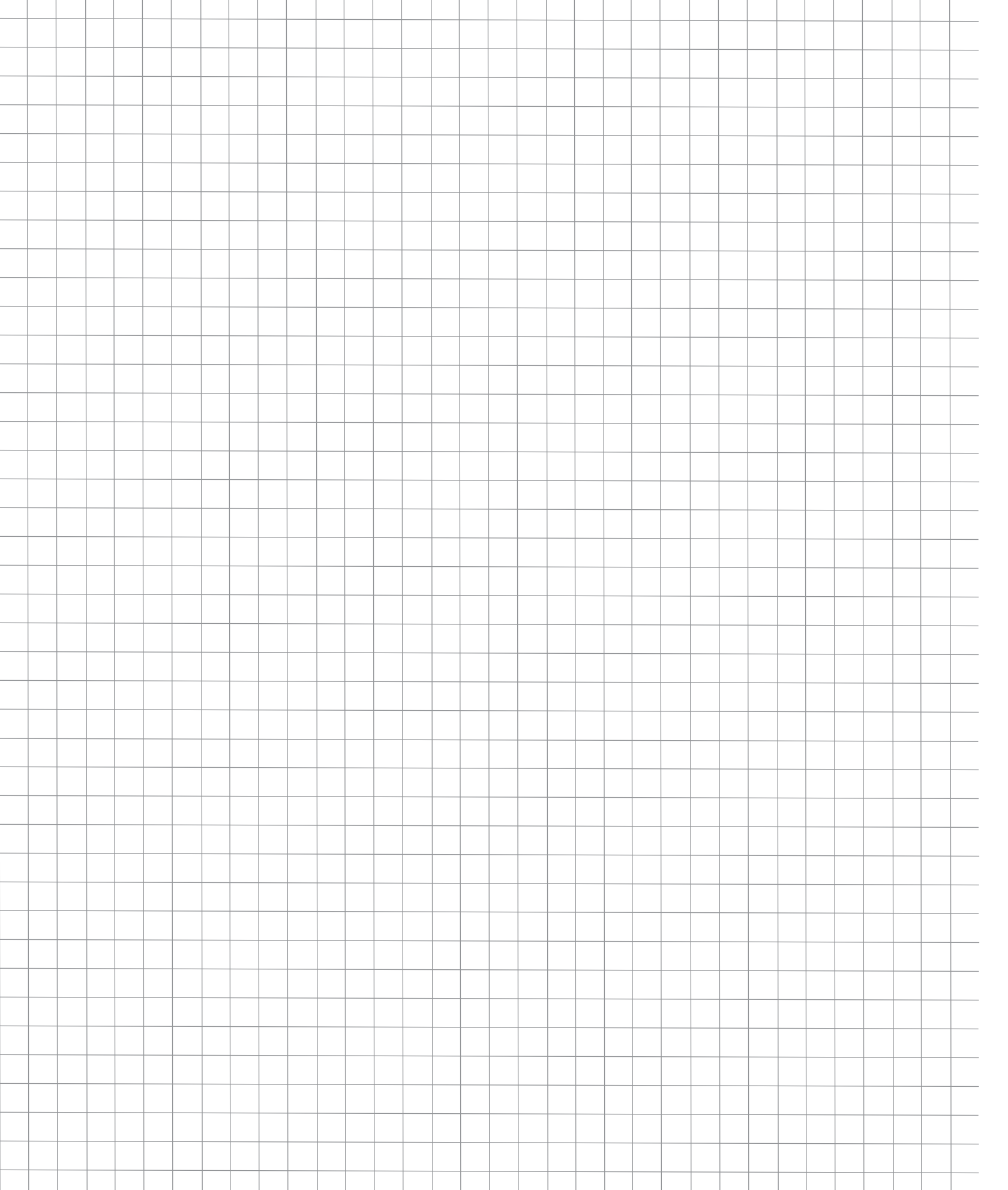

CAR CRASHES

.....

1. Why did the crash dummy fall off the back of the truck when the truck drove off?

2. What do seat belts do for passengers during a car crash?

3. What two factors affect a vehicle's momentum?

4. What happens to a vehicle's momentum when it crashes into a wall?

5. What is a crumple zone, and what advantage does it provide passengers in a crash?

6. What causes injury and death when people are in car crashes?

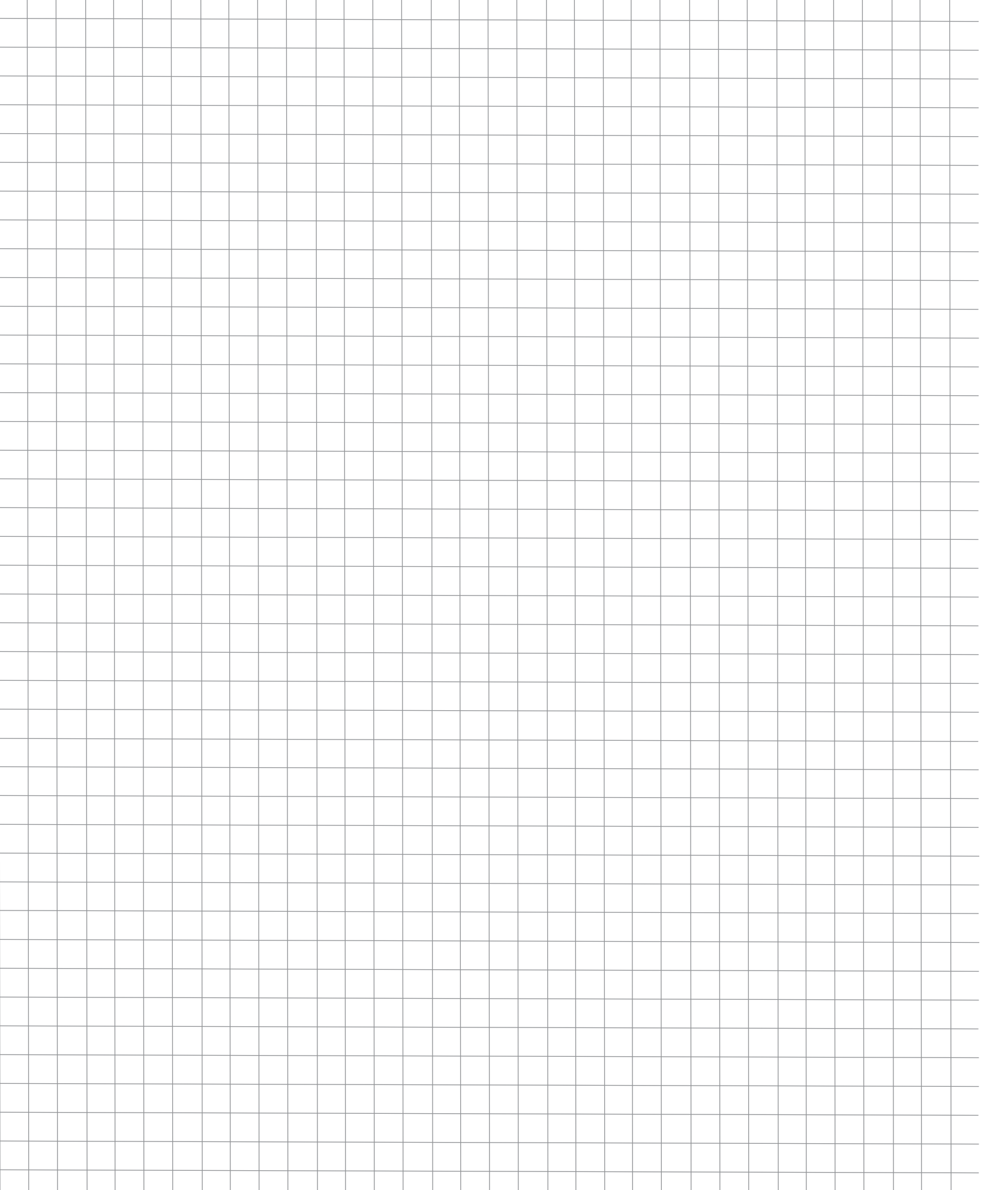

EQUATIONS

<p>Equation for calculating distance (d) when initial and final positions are known</p> $d = x_f - x_i$ <p>x_i = initial position x_f = final position</p>	<p>Equation for calculating speed (v) when distance and time are known</p> $v = \frac{d}{\Delta t}$ <p>d = distance Δt = change of time</p>		
<p>Equation for calculating distance (d) when speed and time are known</p> $d = v \times \Delta t$ <p>v = speed Δt = change of time</p>	<p>Equation for calculating change of time (Δt) when speed and distance are known</p> $\Delta t = \frac{d}{v}$ <p>d = distance v = speed</p>		
<p>Equation for calculating acceleration (a) when change of velocity and time are known</p> $a = \frac{\Delta \bar{v}}{\Delta t}$ <p>$\Delta \bar{v}$ = change of velocity Δt = change of time</p>	<table border="0"> <tr> <td data-bbox="811 1108 1065 1474"> <p>Equation for calculating velocity (\bar{v}) when acceleration and time are known</p> $\bar{v} = a \times t$ <p>a = acceleration t = time</p> </td> <td data-bbox="1105 1108 1412 1474"> <p>Equation for calculating velocity (\bar{v}) when change of position and time are known</p> $\bar{v} = \frac{\Delta x}{\Delta t}$ <p>Δx = change of position Δt = change of time</p> </td> </tr> </table>	<p>Equation for calculating velocity (\bar{v}) when acceleration and time are known</p> $\bar{v} = a \times t$ <p>a = acceleration t = time</p>	<p>Equation for calculating velocity (\bar{v}) when change of position and time are known</p> $\bar{v} = \frac{\Delta x}{\Delta t}$ <p>Δx = change of position Δt = change of time</p>
<p>Equation for calculating velocity (\bar{v}) when acceleration and time are known</p> $\bar{v} = a \times t$ <p>a = acceleration t = time</p>	<p>Equation for calculating velocity (\bar{v}) when change of position and time are known</p> $\bar{v} = \frac{\Delta x}{\Delta t}$ <p>Δx = change of position Δt = change of time</p>		
<p>Equation for calculating distance (d) when acceleration and time are known</p> $d = \frac{a \times t^2}{2}$ <p>a = acceleration t = time</p>	<p>Equation for calculating momentum (p) when mass and velocity are known</p> $p = m \times \bar{v}$ <p>m = mass \bar{v} = velocity</p>		

NOTES

NOTES