

LETTER TO PARENTS

Cut here and paste onto school letterhead before making copies.

SCIENCE NEWS

Dear Parents,

Our class is beginning a study of air and weather. Students will be looking for evidence that air is matter—that it is something real. They will explore the properties of air using plastic syringes and tubing. They will observe how air can be captured, how air can be compressed, and how air under pressure can move things around. They will observe daily weather conditions such as temperature, rainfall, cloud cover, wind speed, and wind direction. They will be recording all of this information on a class calendar and in a science journal.

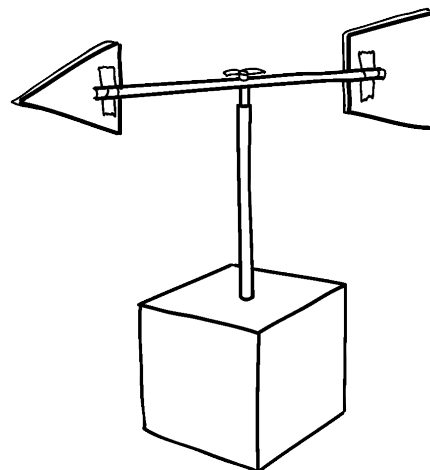

You can help your child learn more about weather, too. You might discuss weather reports in the newspaper or on television. Point out wind vanes if you happen to see one perched on top of a house. If you have an indoor or outdoor thermometer, read and record the temperature at about the same time each day and look for patterns. Or you may want to watch the temperature change over the course of one day. Does it happen that way every day? Weather is an ever-changing story. You can guide your child's scientific inquiry by helping him or her to make observations and by nurturing his or her natural ability to ask questions based on those observations. Don't be surprised if you end up with a list of questions much longer than the initial observations!

If you have any questions or comments, call or come in and visit our class.

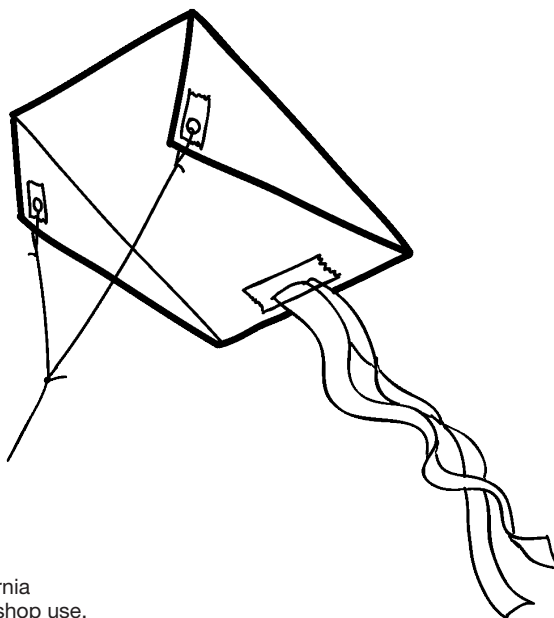

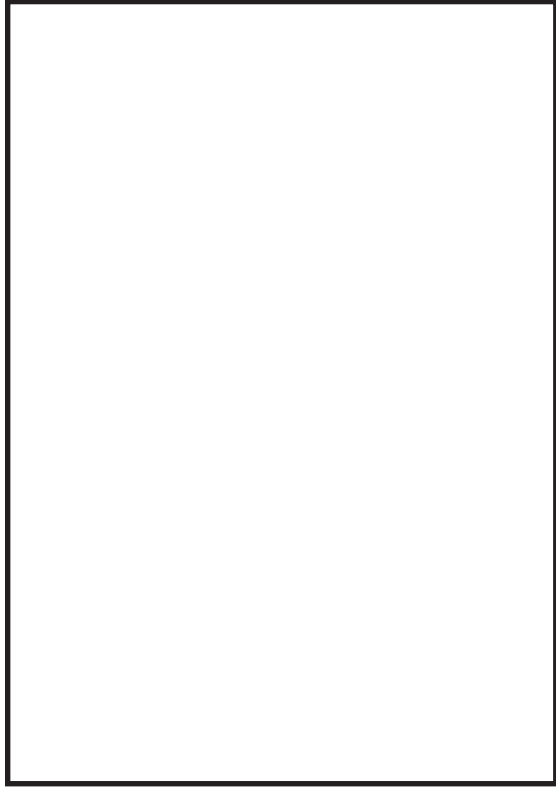

Today's Date _____

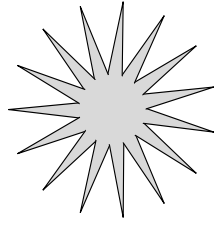

Air and Weather Journal



This journal belongs to _____

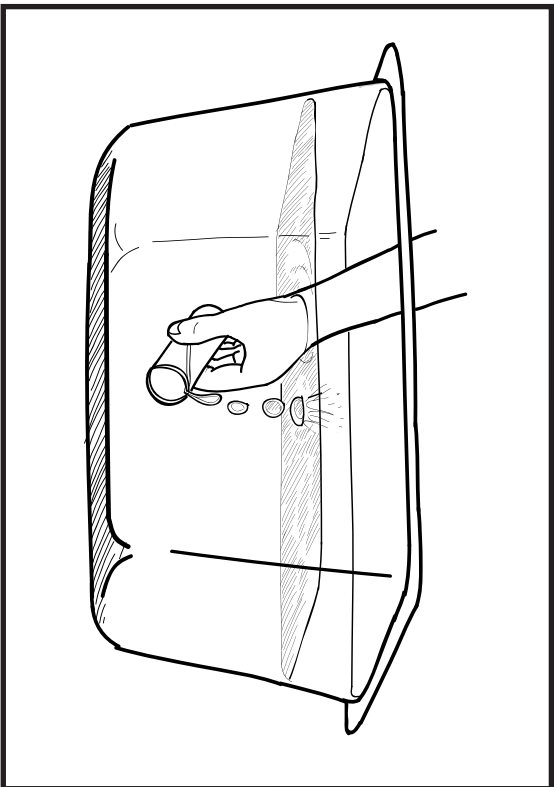

Today's Date _____

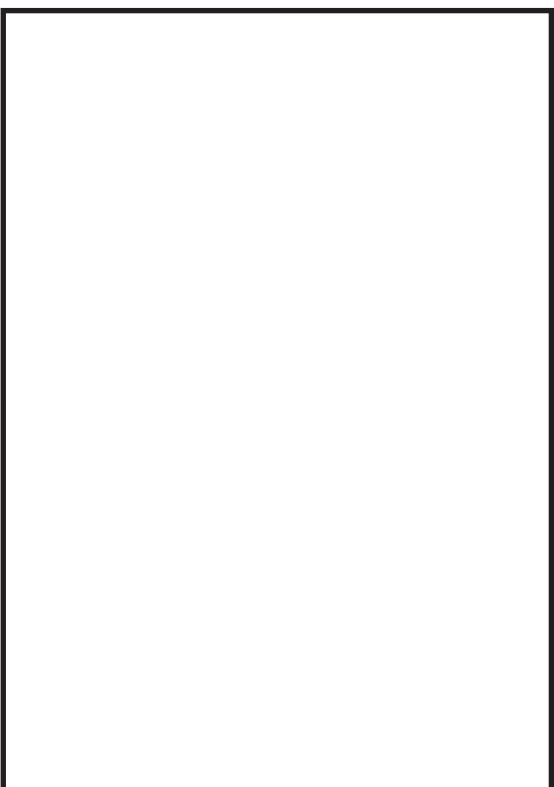

Today's Date _____

WEATHER/WIND VANE..... **PAGE 10**.....

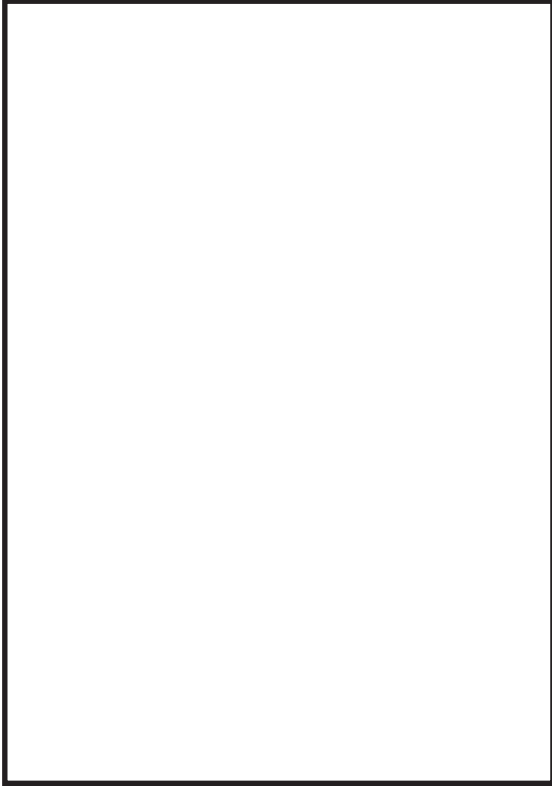

Today's Date _____

KEEP THE TOWEL DRY..... **PAGE 3**.....

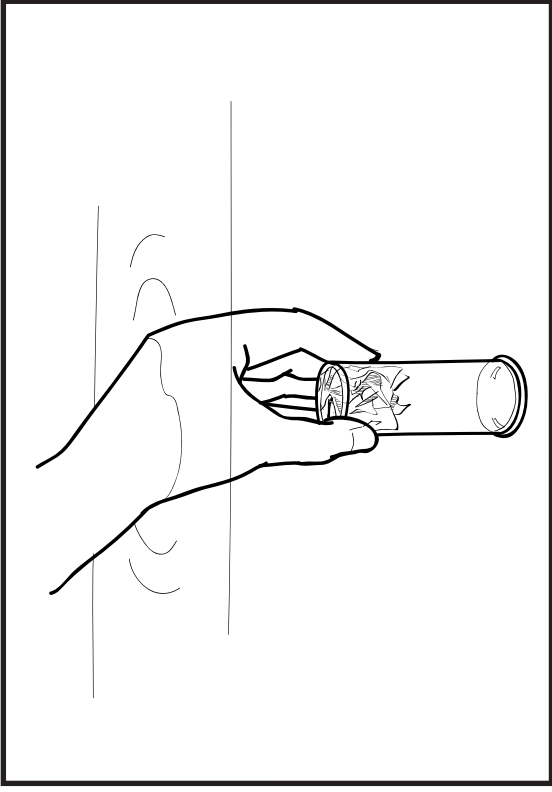

Today's Date _____

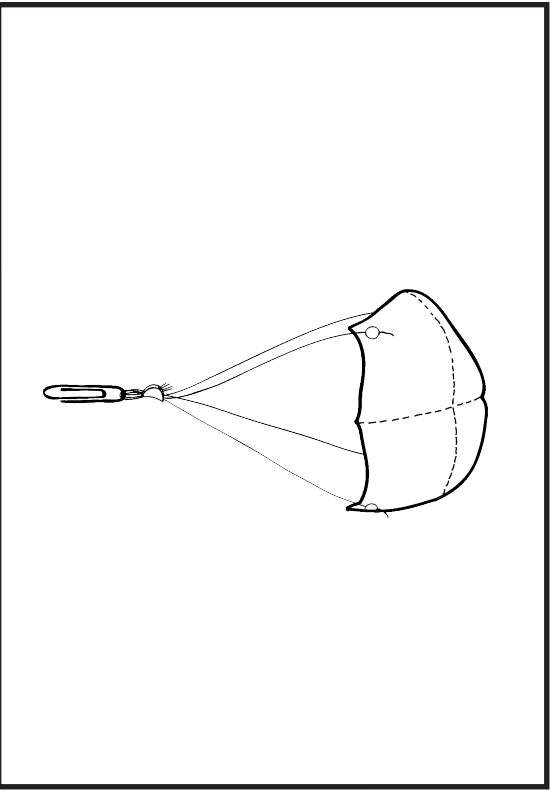

Today's Date _____

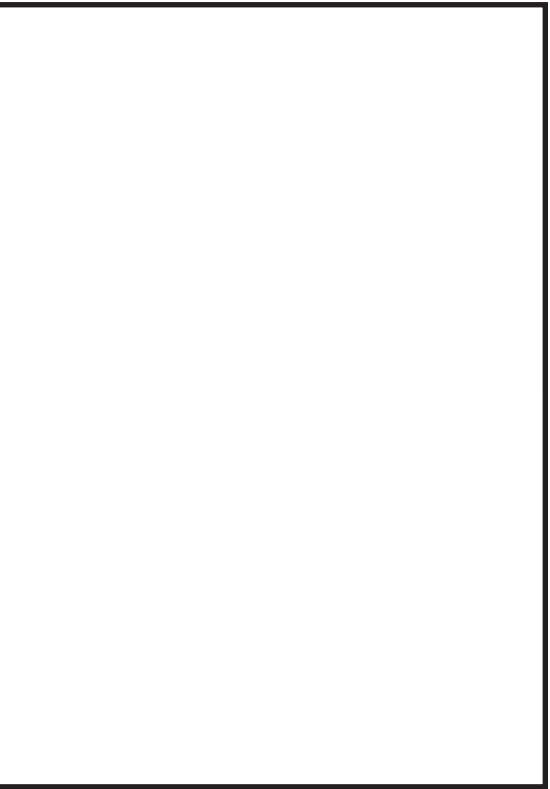

Today's Date _____

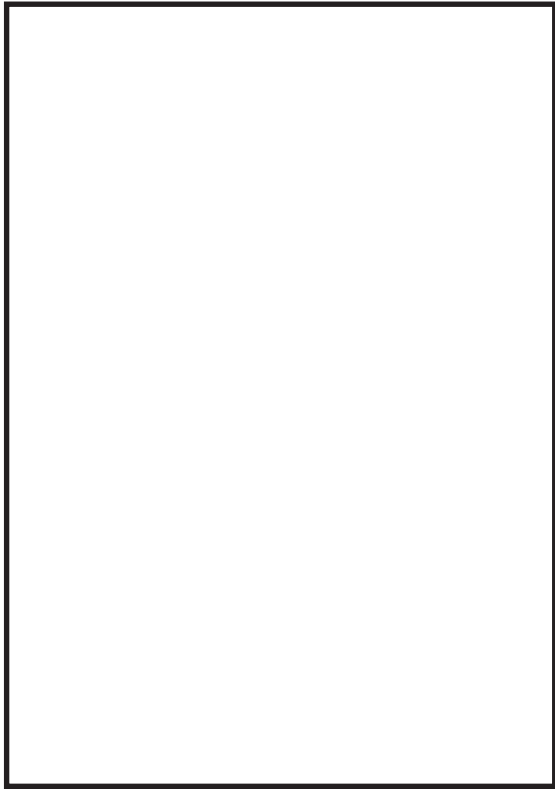

Today's Date _____

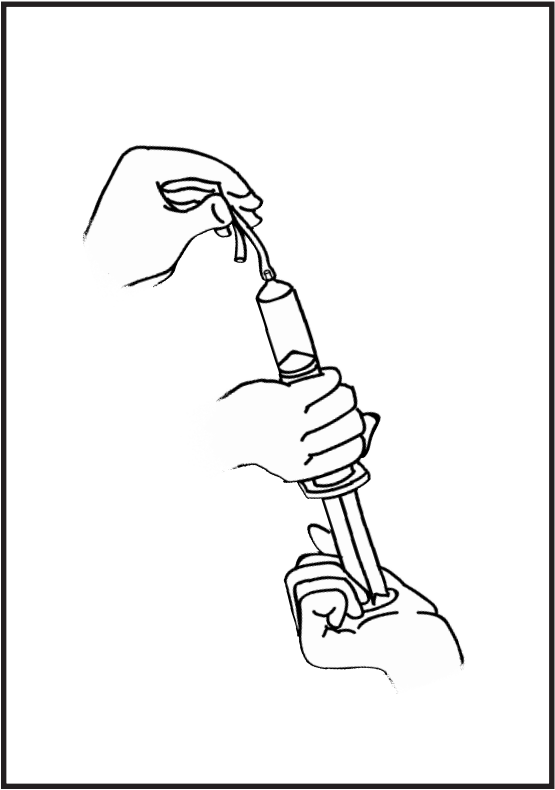

Today's Date _____

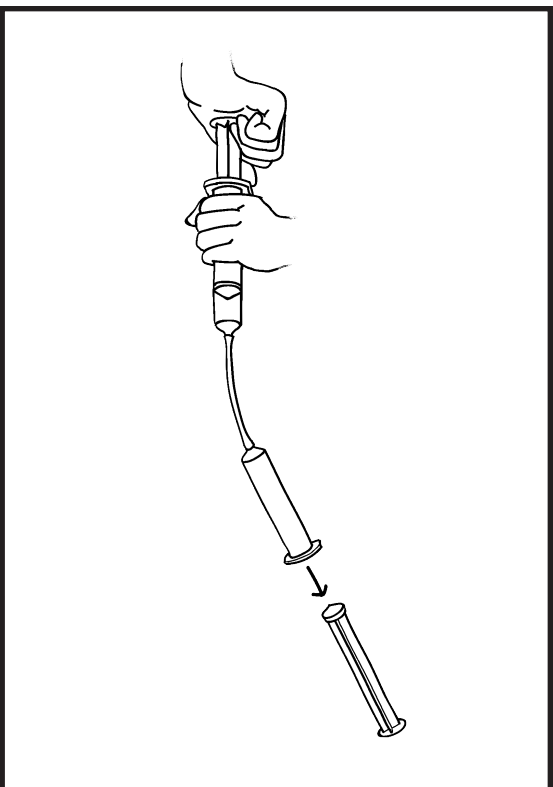

Today's Date _____

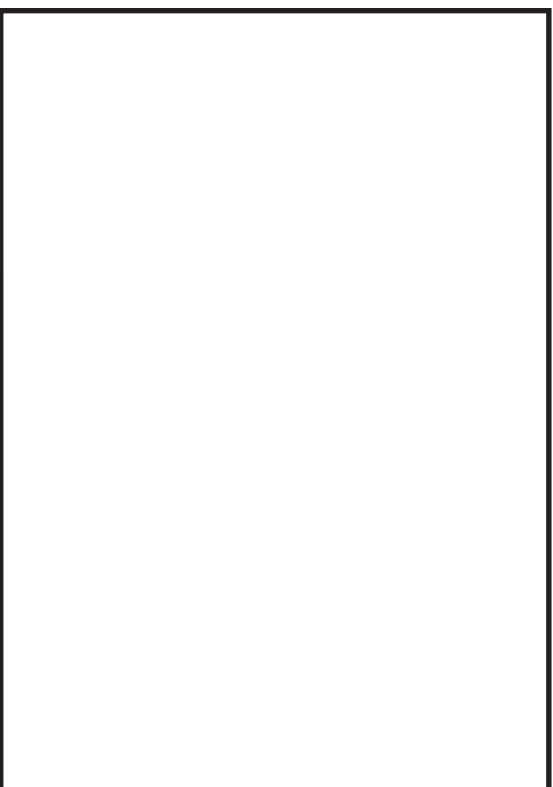

Today's Date _____

CENTER INSTRUCTION CARD—AIR UNDER WATER

Materials for Each Station

- | | | | |
|---|-------------------------|---|------------------------------------|
| 1 | Basin of water | 4 | Uncut paper towels |
| 8 | Quarters of paper towel | • | Extra quarters of cut paper towels |
| 4 | Vials | | |

Set Up the Center

Fill the basins with water.

Cut the paper towels into fourths. (Keep extra paper towels at hand.)

Guide the Investigation

- 1. Introduce the Investigation.** Distribute the vials to each student. Ask students to find out as much as they can about air using these materials. Let them explore for 5 to 8 minutes.
- 2. Discuss Observations.** Have students remove vials from the water and place them out of reach. Focus discussion around discoveries that students have made about air.
 - *Is there air in the vial? How do you know?*
 - *If you push the vial straight down into the water, is the air still in the vial? How do you know?*
 - *Where do the bubbles come from?*
- 3. Set a New Challenge.** Have students use a paper towel to dry their vials completely. Every drop must be wiped out. Show them how to push a paper towel into the vial. Then give them the challenge,
 - *Can you submerge the vial and still keep the paper towel dry?*

Distribute the quarters of paper towel. As students investigate, ask,



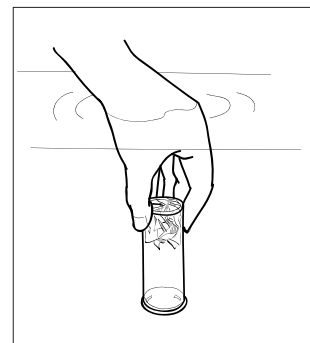











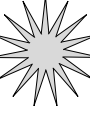
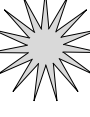













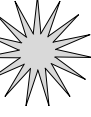
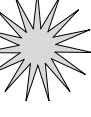



- *How did you keep your paper towel dry?*
- *Where is the air?*
- *How can you tell the air is there?*

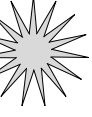
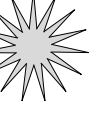

- 4. Prepare the Center for the Next Group.** When time is nearly up, have students dry off their vials, hands, and table. Add water as needed to the basins.

WEATHER SYMBOLS

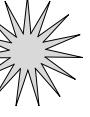
Cut symbols apart and place in cups or envelopes for daily use with class calendar.

 OVERCAST	 OVERCAST	 RAINY	 RAINY	 SNOWY	 SUNNY	 SUNNY	 PARTLY CLOUDY
 OVERCAST	 OVERCAST	 RAINY	 RAINY	 SNOWY	 SUNNY	 SUNNY	 PARTLY CLOUDY
 OVERCAST	 OVERCAST	 RAINY	 RAINY	 SNOWY	 SUNNY	 SUNNY	 PARTLY CLOUDY
 OVERCAST	 OVERCAST	 RAINY	 RAINY	 SNOWY	 SUNNY	 SUNNY	 PARTLY CLOUDY
 OVERCAST	 OVERCAST	 RAINY	 RAINY	 SNOWY	 SUNNY	 SUNNY	 PARTLY CLOUDY

THERMOMETER PICTURES °C

Cut pictures apart. Each student needs one picture.

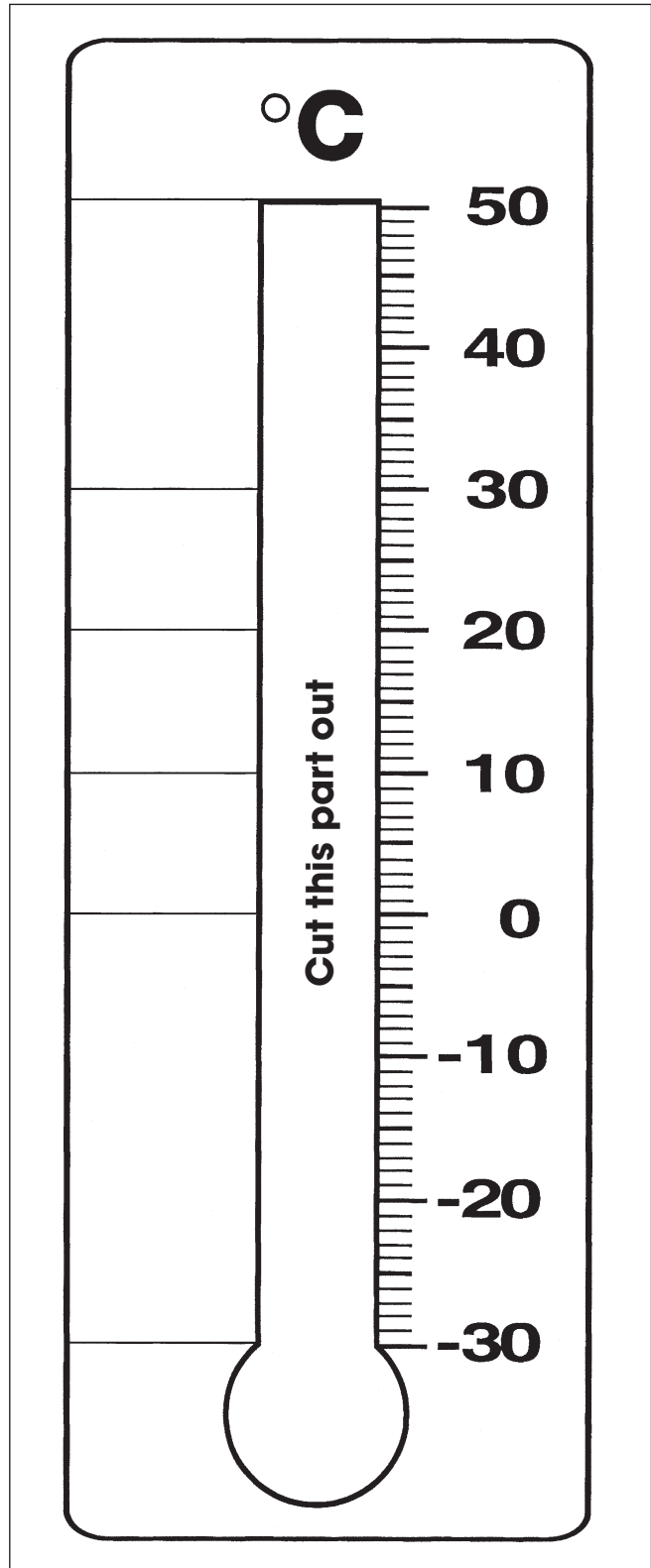
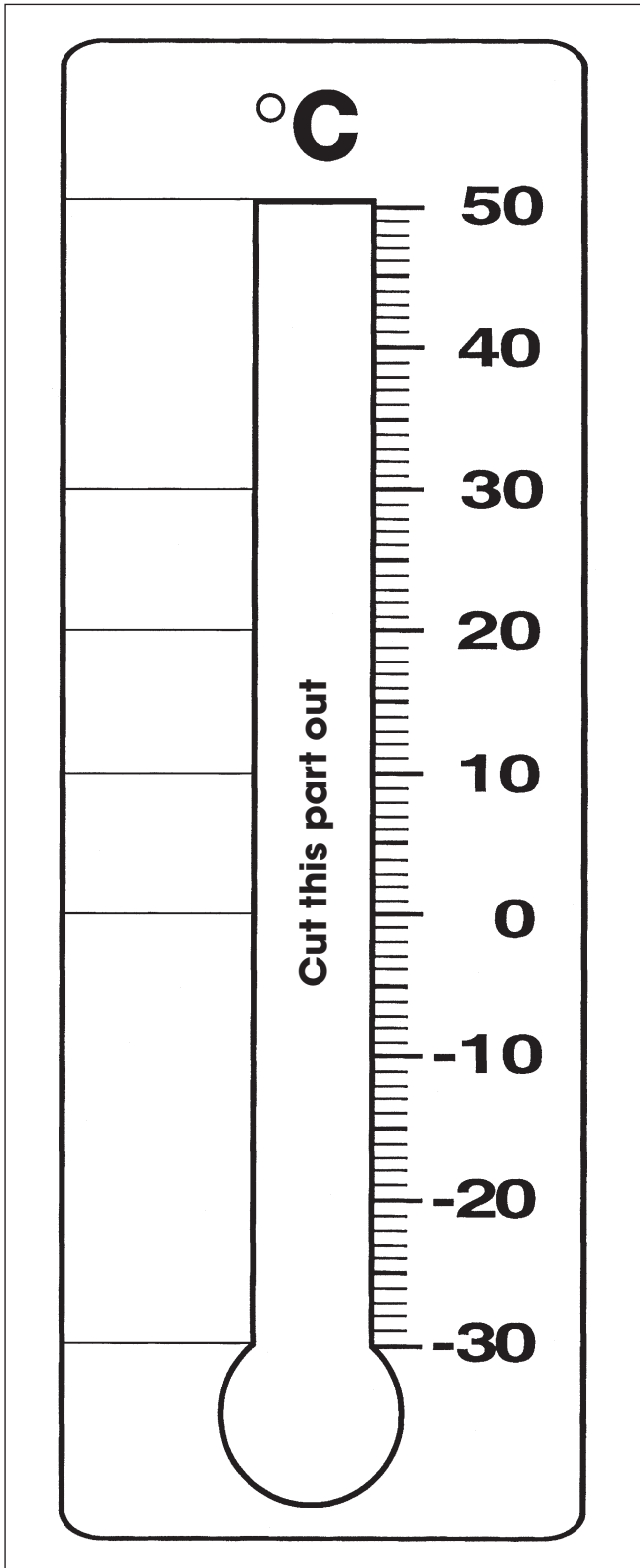

THERMOMETER PICTURES °F

Cut pictures apart. Each student needs one picture.

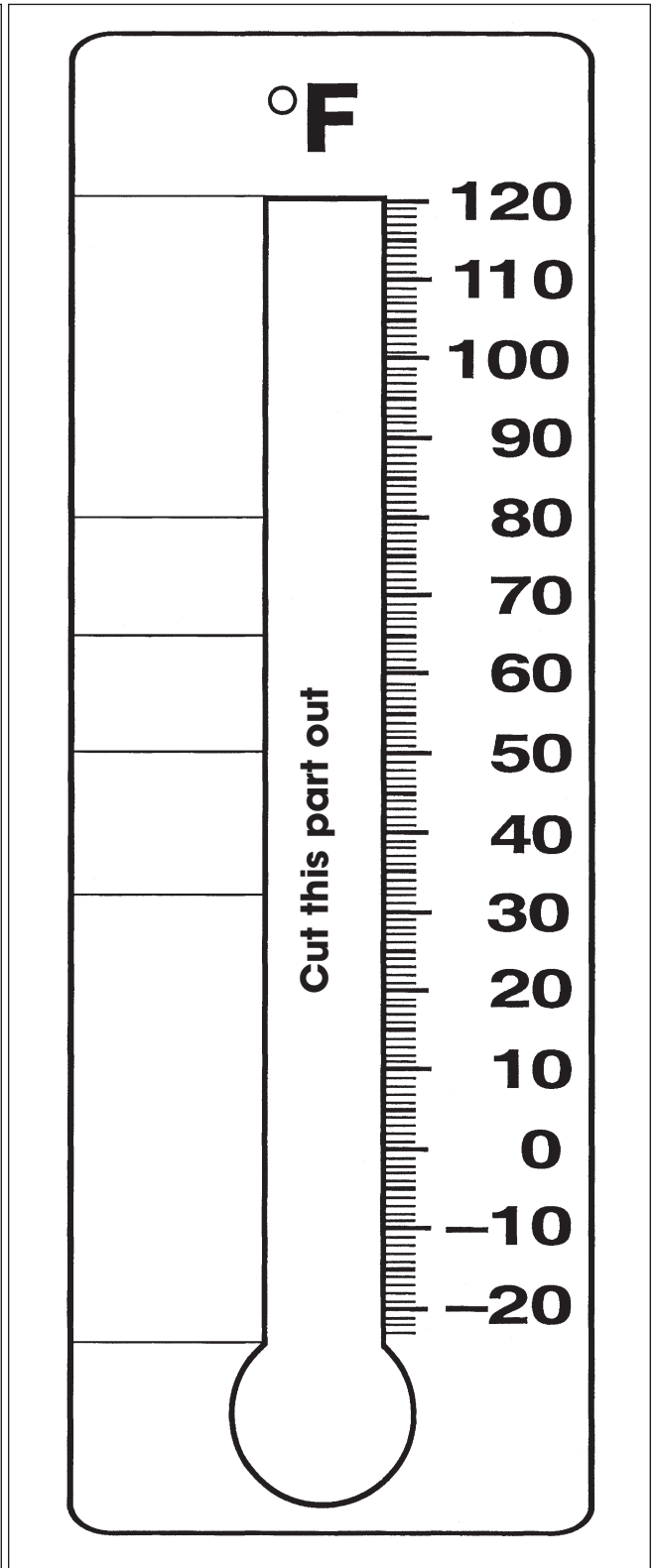
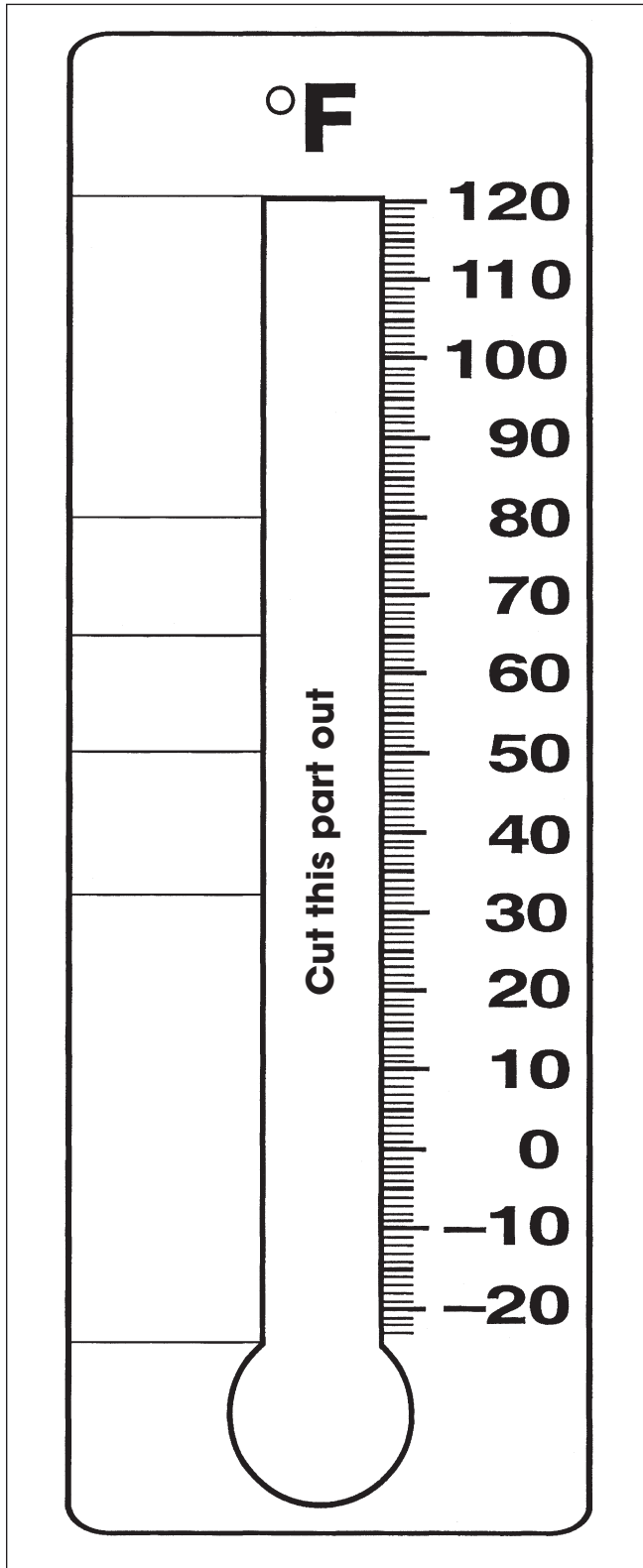

Name _____

CLOUD TYPES

.....



MAKE A RAIN GAUGE

MATERIALS

- 1 Soda bottle, 2-liter
- 1 Mat knife or scissors
- Duct tape
- 1 Permanent marking pen, fine-tip
- 1 Cup of pebbles or marbles
- 1 Ruler

CONSTRUCTION

1. Discard the bottle cap. Measure up 18 cm (7") from the bottom as shown. Cut the soda bottle into two pieces. Cut a flap about 2 cm (1") on a side 5 cm (2") below this cut. This will allow you to pour water out of the gauge to return to zero after rain has been collected and measured.
2. Add a cup of pebbles or marbles to the base of the soda bottle.
3. Turn the top of the soda bottle over to make a funnel. Insert it into the bottle base. Use duct tape to join the two pieces.
4. You will measure rain in centimeters or inches. Measure up 7 cm (3") from the base and draw a line with the permanent marking pen. Label this baseline "0." From here measure and mark each centimeter with a line. Mark and label six lines: 1 cm, 2 cm, and so forth. (If inches are used, mark and label each half inch.)
5. To use the rain gauge, add water to the zero line. Place the rain gauge outside in an open area (no overhangs) where it will not be disturbed while collecting rain.

NOTE: Add more pebbles or marbles for ballast if you live in a windy area.

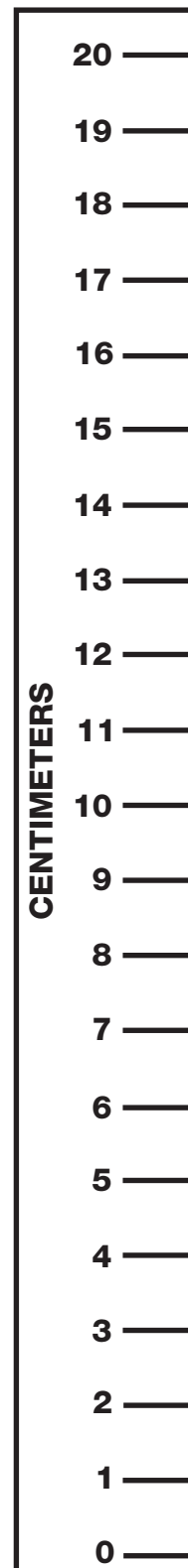
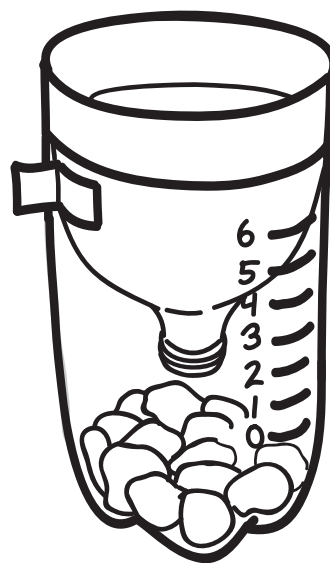
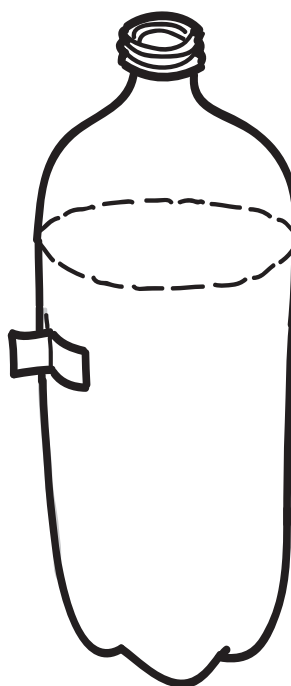

RAIN-GAUGE PICTURES

Cut pictures apart. Each student needs one picture.

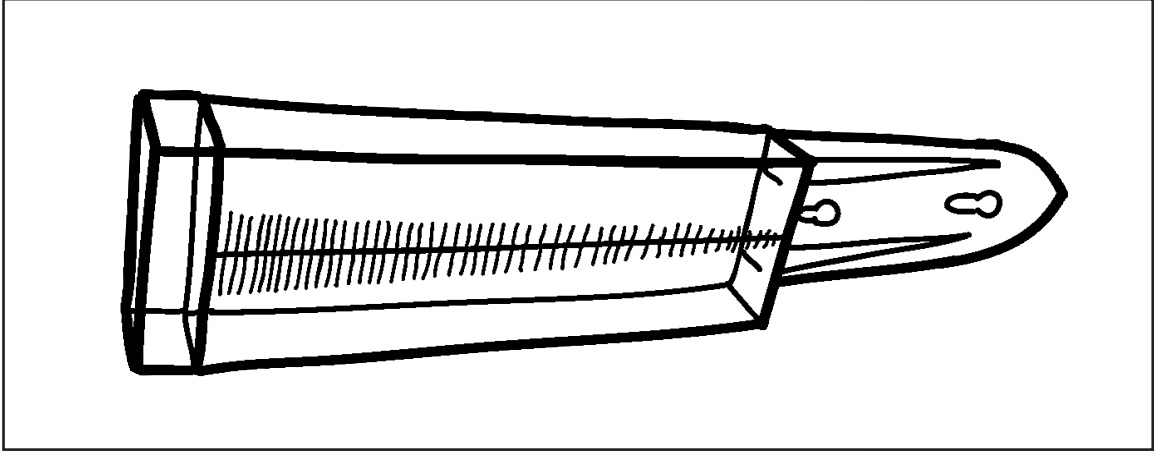
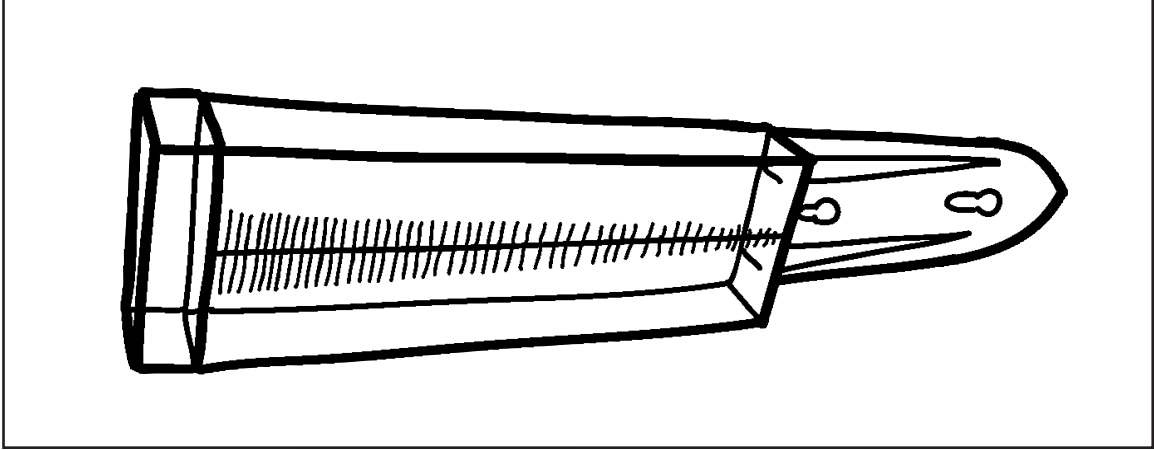
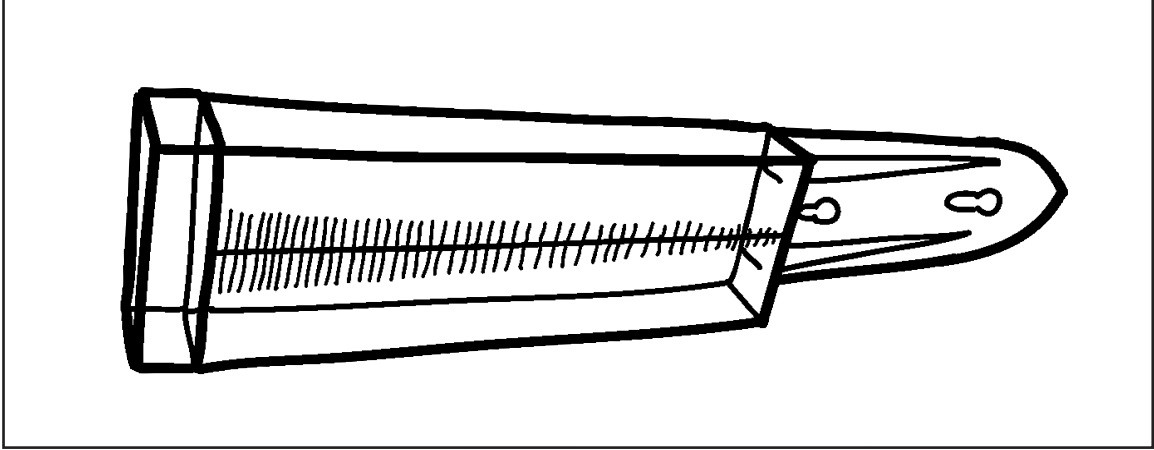
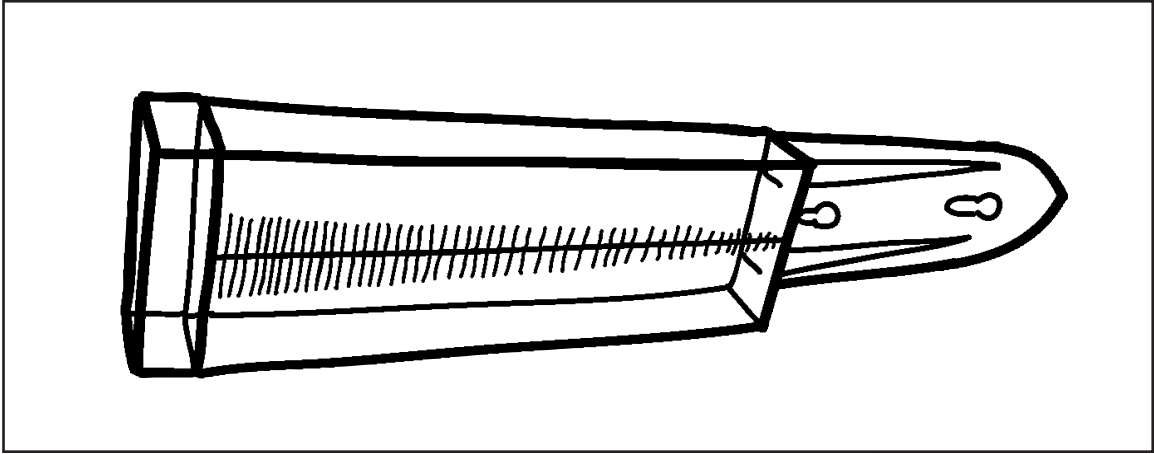

WIND SCALE

NO WIND, OR CALM

Smoke goes straight up.
Leaves don't move.



GENTLE BREEZE

Leaves rustle. Smoke drifts.
You can feel the wind on your face.
Small twigs on trees bend.
Flags and streamers flutter or stand out and wave.



MODERATE BREEZE

Small papers and leaves blow
across the ground.
Small branches in trees move.



STRONG BREEZE

Large tree branches shake.
Kites fly high.
Umbrellas may turn inside out.
Wind whistles through the wires.

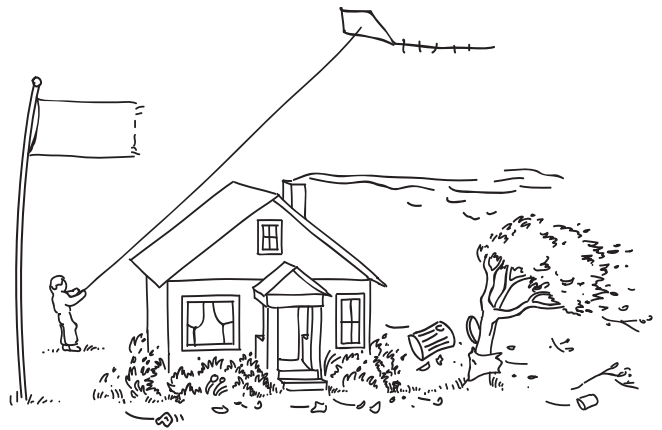

ANEMOMETER CONSTRUCTION

MATERIALS

- 4 Plastic cups
- 1 Wooden base
- 1 Cardboard square, corrugated
- 1 Straw, super jumbo
- 1 Straw, jumbo
- Tape
- 1 Scissors
- 1 Permanent marking pen, black

CONSTRUCTION

1. Insert one cup all the way into each slit in the cardboard square. This will be easier if you cut the rolled lip from the cup at the location where you slide it over the cardboard square. Make a large black mark on one cup as a reference point.
2. Use scissors to cut a 1-cm (1/2") slit in the end of a *jumbo* straw. Insert the split end of the straw through the hole in the cardboard. Fold the flaps of the straw outward. Secure the flaps with a piece of tape.
3. Cut 5 cm (2") off the *super jumbo* straw and insert the long part into the hole in the wooden block. Push the straw into the block as far as it will go.
4. Insert the jumbo straw with the anemometer attached into the super jumbo straw. When you blow at the cups, the anemometer should rotate in the super jumbo straw. Your anemometer is ready to use.

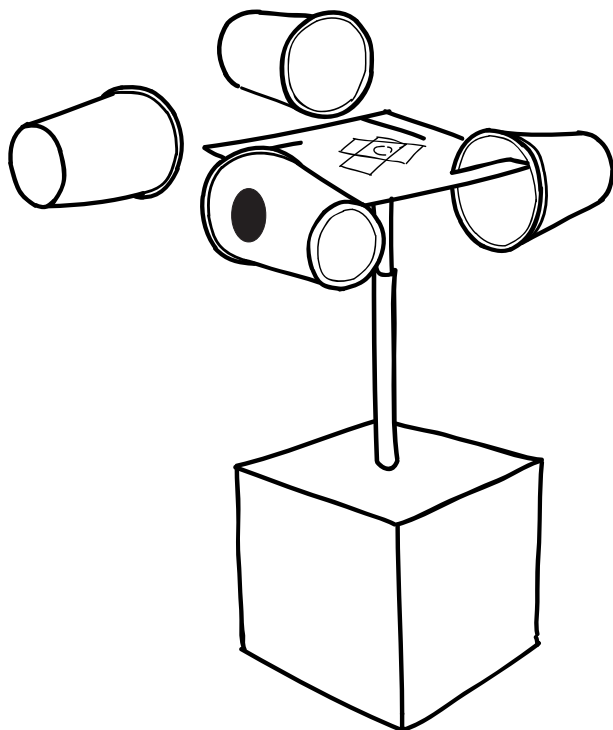

PINWHEEL PATTERNS

Cut pictures apart. Each student needs one picture.

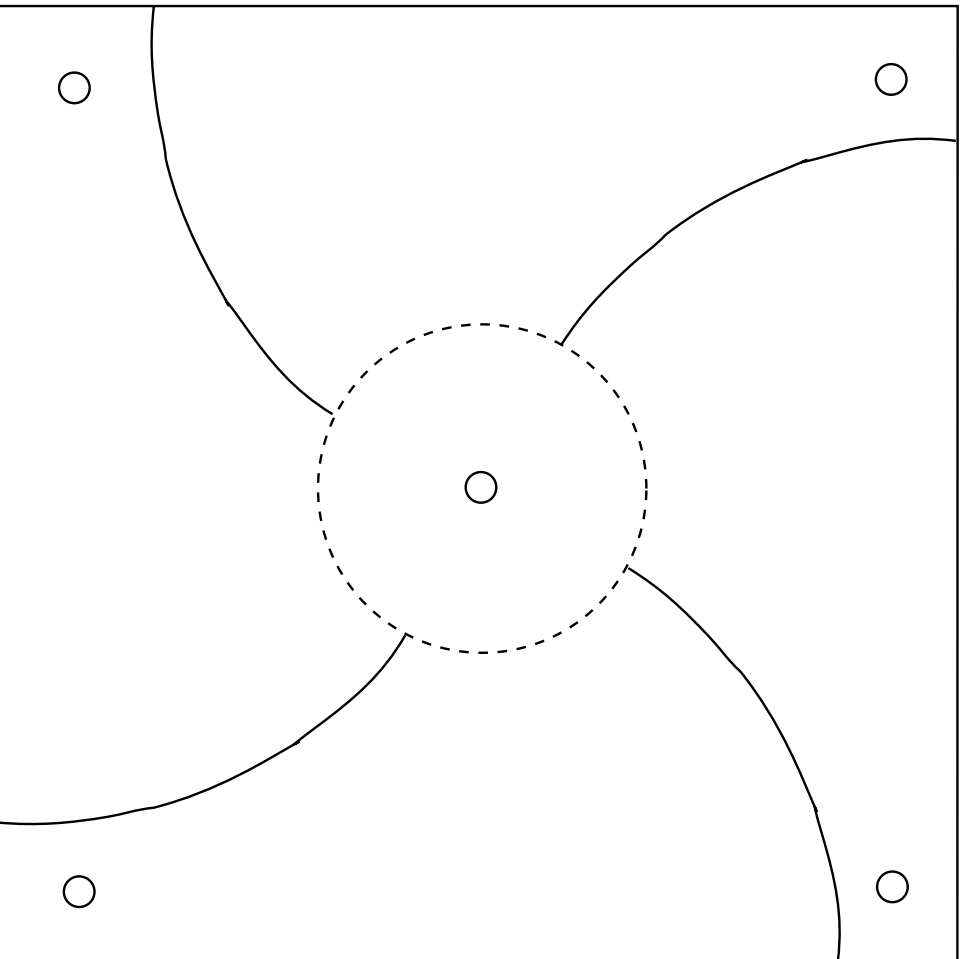
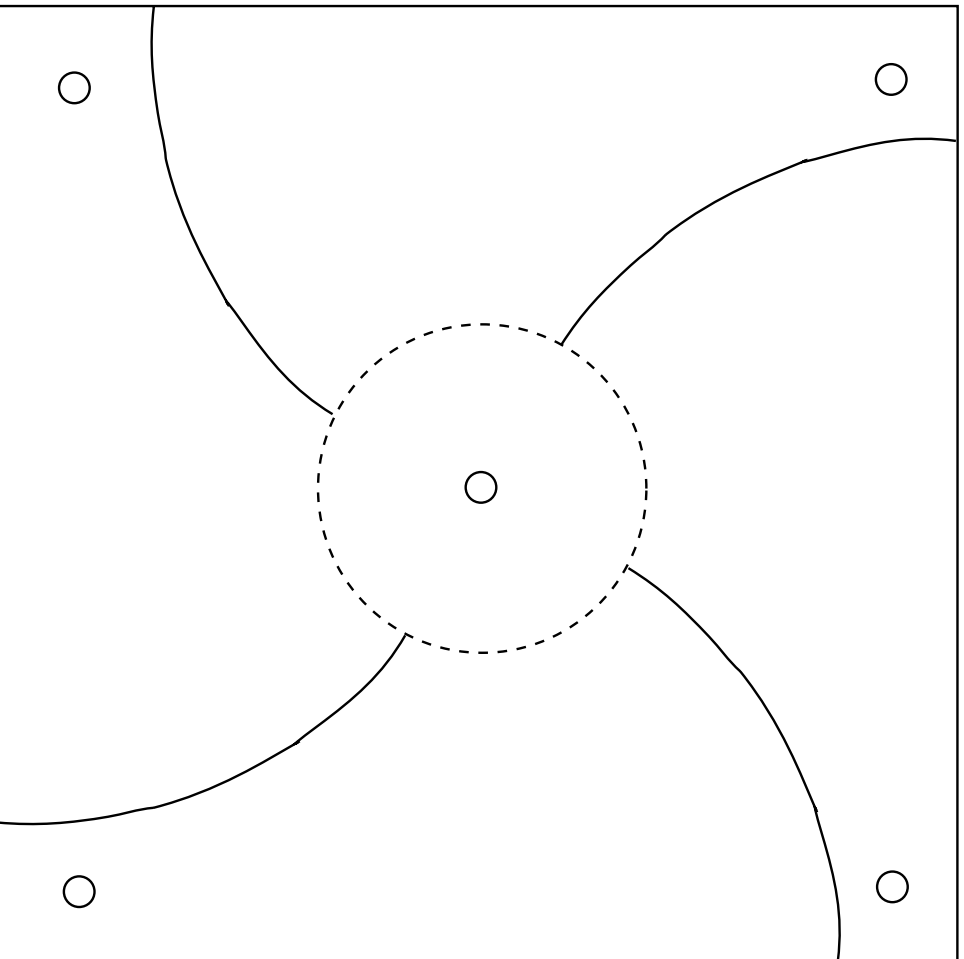

WIND-VANE CONSTRUCTION

MATERIALS

- 1 Piece of lightweight cardboard
- 1 Straw, jumbo
- 2 Straws, super jumbo
- 1 Wooden base
- 1 Hole punch
- Tape
- 1 Scissors

CONSTRUCTION

1. Cut a triangle from light cardboard (index card or file folder). Cut as indicated to make a point and a rudder.
2. Use the hole punch to punch a hole in a super jumbo straw a little closer to one end.
3. Cut a 1-cm (1/2") slit in one end of a jumbo straw (smaller than super jumbo).
4. Insert the split end of the jumbo straw through the hole in the super jumbo straw. Fold down the flaps of the jumbo straw and tape them to the super jumbo straw.
5. Cut 1-cm (1/2") slits in the super jumbo straw. Insert the cardboard pieces in the straw, as shown. The arrow point should be on the short end of the straw (the shorter distance from the hole). Secure the cardboard with small pieces of tape on both sides.
6. Insert another super jumbo straw in the wooden base. Insert the jumbo straw with the wind-vane assembly into this super jumbo straw. Your wind vane is ready to use.

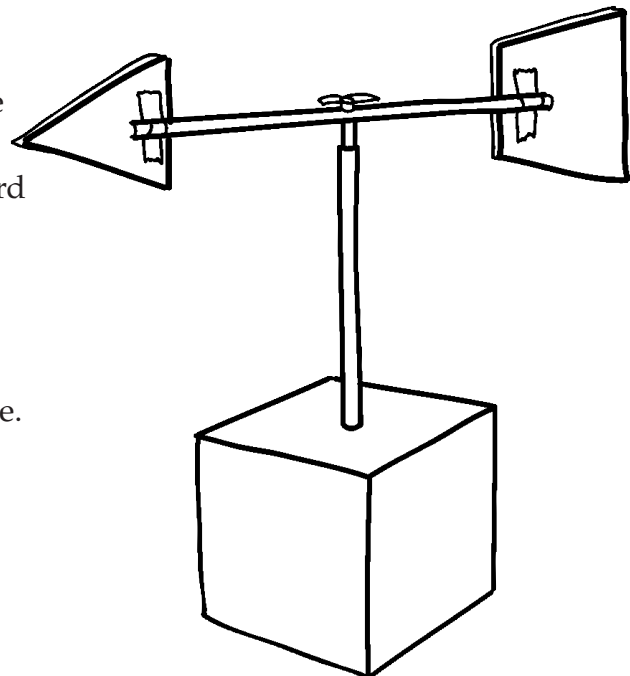
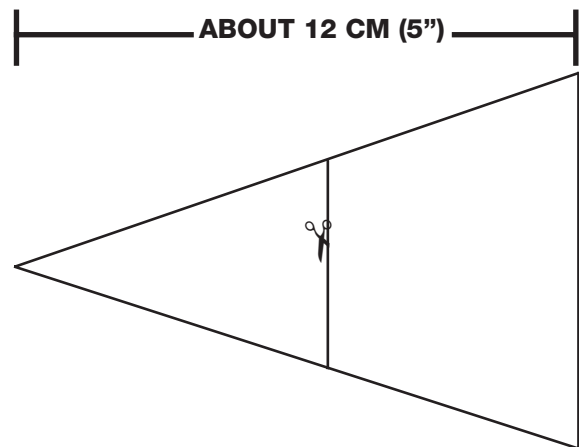

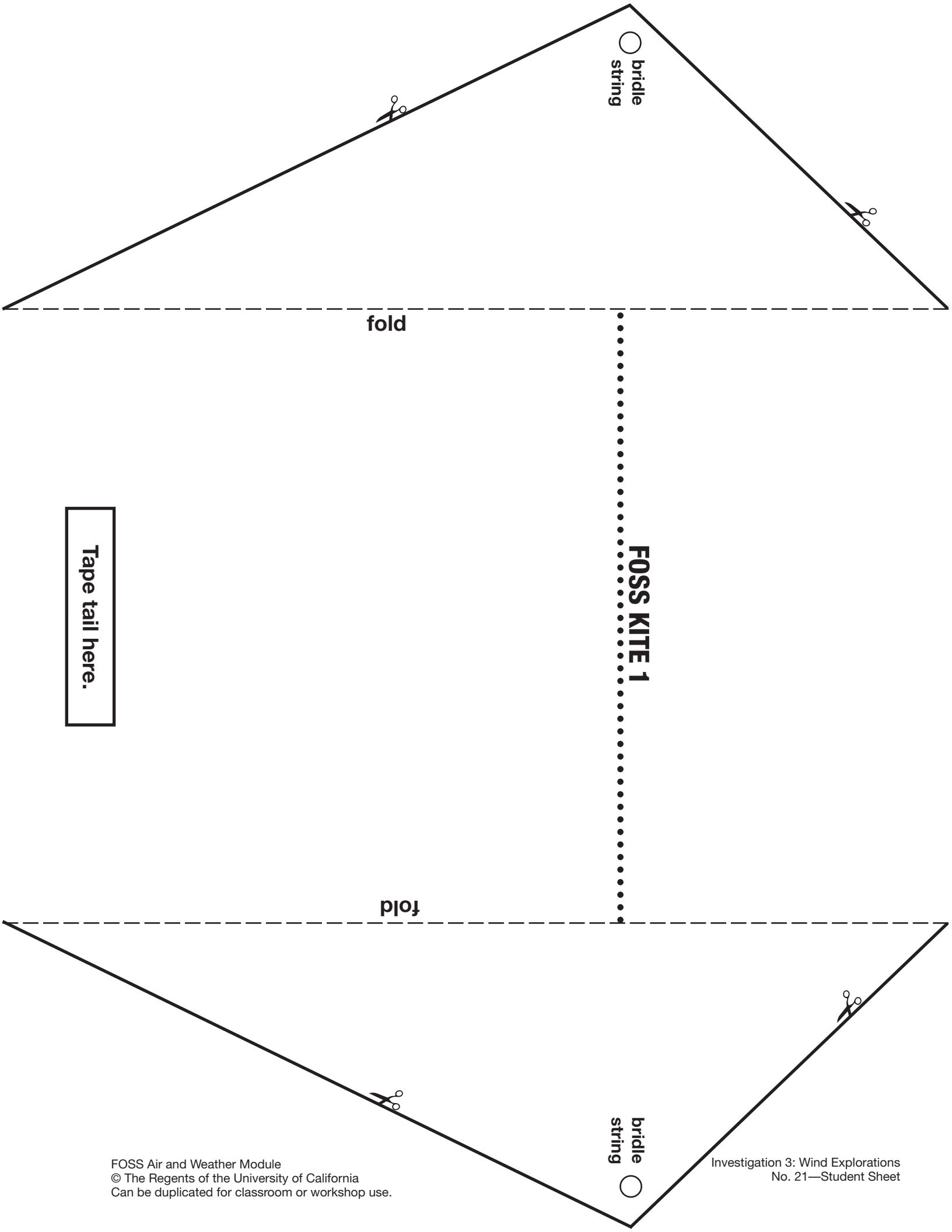

○
bridle
string

fold

FOSS KITE 1

fold

○
bridle
string

Tape tail here.

FOSS KITE 2

Fold down. ⑥

⑤ Tape straw here

tape

ta

Fold down.

③

④

ta

⑧

Tape tail

Fold together here.

①

Fold down.

②

pe

⑨

Turn the kite over to add a hole and string.

here.

⑦ Fold down.

tape

FOSS KITE 2

ANEMOMETER PICTURE

Cut pictures apart. Each student needs one picture.

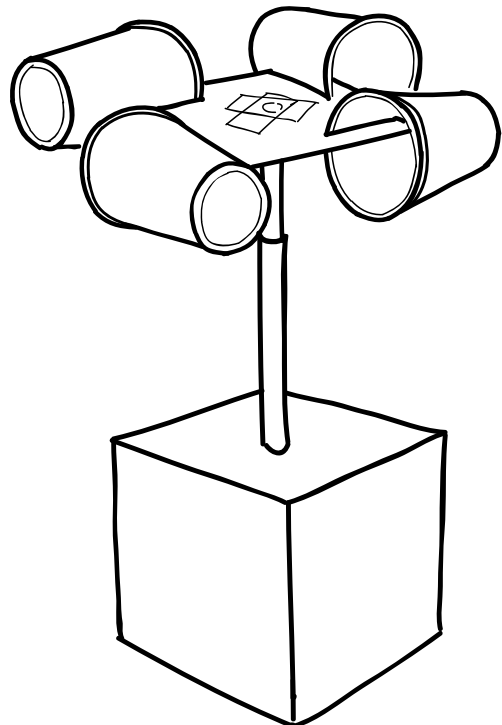
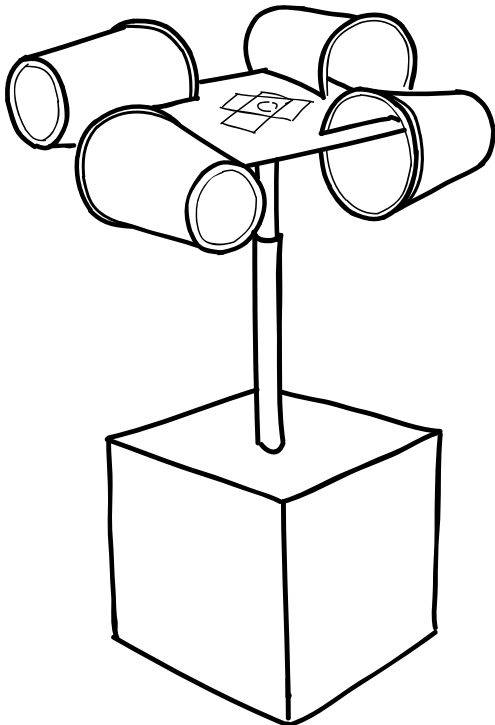
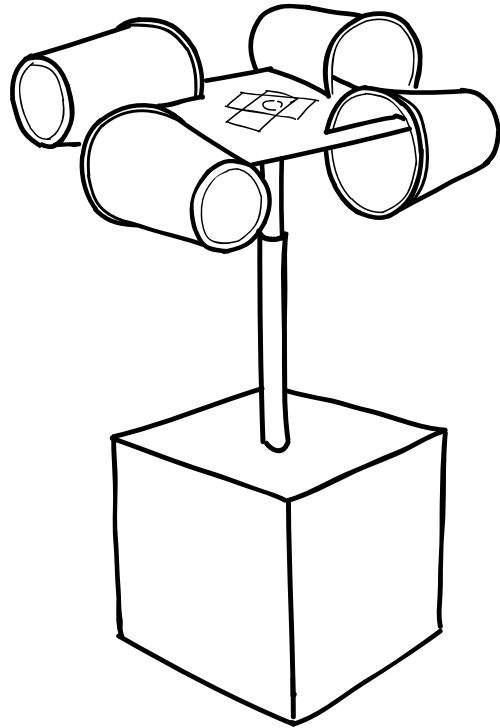
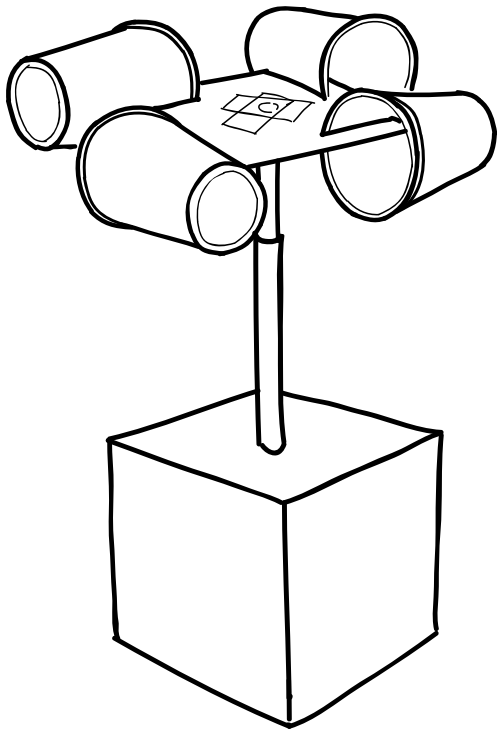

WEATHER RECORD

FROM _____ TO _____

SUNDAY	MONDAY	TUESDAY	WEDNESDAY	THURSDAY	FRIDAY	SATURDAY

Name _____

WEATHER GRAPH





.....

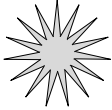

FROM _____

TO _____

GRAPH CATEGORIES

 SUNNY	 PARTLY CLOUDY	 OVERCAST	 RAINY	 SNOWY
---------------------------------------------------------------------------------------------------	-----------------------------------------------------------------------------------------------------------	------------------------------------------------------------------------------------------------------	----------------------------------------------------------------------------------------------------	-----------------------------------------------------------------------------------------------------

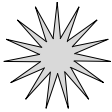
 SUNNY	 PARTLY CLOUDY	 OVERCAST	 RAINY	 SNOWY
---------------------------------------------------------------------------------------------------	-----------------------------------------------------------------------------------------------------------	------------------------------------------------------------------------------------------------------	----------------------------------------------------------------------------------------------------	-----------------------------------------------------------------------------------------------------

 SUNNY	 PARTLY CLOUDY	 OVERCAST	 RAINY	 SNOWY
---------------------------------------------------------------------------------------------------	-----------------------------------------------------------------------------------------------------------	------------------------------------------------------------------------------------------------------	----------------------------------------------------------------------------------------------------	-----------------------------------------------------------------------------------------------------

freezing below 32°F	cold 32°–50° F	cool 50°–65°F	warm 65°–80°F	hot above 80°F
------------------------	-------------------	------------------	------------------	-------------------

freezing below 32°F	cold 32°–50°F	cool 50°–65°F	warm 65°–80°F	hot above 80°F
------------------------	------------------	------------------	------------------	-------------------

freezing below 32°F	cold 32°–50°F	cool 50°–65°F	warm 65°–80°F	hot above 80°F
------------------------	------------------	------------------	------------------	-------------------

freezing below 0°C	cold 0°–10°C	cool 10°–18°C	warm 18°–27°C	hot above 27°C
-----------------------	-----------------	------------------	------------------	-------------------

freezing below 0°C	cold 0°–10°C	cool 10°–18°C	warm 18°–27°C	hot above 27°C
-----------------------	-----------------	------------------	------------------	-------------------

PRECIPITATION RECORD—CENTIMETERS

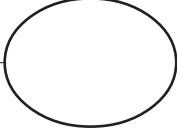
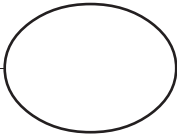
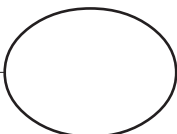
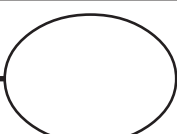
		
		
		
		
Today	cm rain or snow	Total for season
Season:		

PRECIPITATION RECORD—INCHES

.....

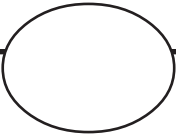
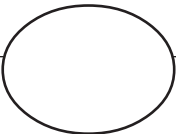
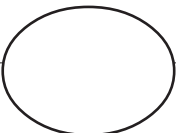
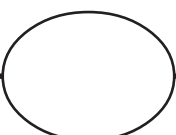
		
		
		
		
Today	inches rain or snow	Total for season
Season:		

NIGHT-SKY LETTER TO PARENTS



Dear Parents,

We have been studying air and weather. We have observed and recorded weather conditions, temperature, rainfall, wind, and clouds on a class calendar and in our *Air and Weather Journals*. Now it is time for us to study the night sky. Since we aren't in school at night, this must be a homework assignment. As a bridge to what we have been studying in class, we have asked students to look for weather in the night sky when they are at home.

To make night-sky observations, take your child outside at about the same time each evening (when it's dark) and observe the sky. Take a few minutes to enjoy the night sky together. Talk about what you see. For example, if it's cloudy, you won't see anything but clouds. If it's clear, you will see stars (you might want to point out a constellation or two), planets (points of light that appear larger and brighter than stars), and the Moon if it is visible. Discuss the changes in the night sky from night to night, especially the changing appearance of the Moon, and where you see it in the sky. (If you don't see the Moon during the night, you might look for it during the day. You can check your local newspaper to find out when it rises.)

Have your child record his or her observations on the *Night-Sky Home Log* (attached) during the week and bring it to school on Friday morning. To complete an entry in the journal, your child records the date and the temperature if you have a thermometer handy. Then have your child write a few sentences about what he or she observed and draw a picture to show what the Moon looks like.

Thanks for your help!

Night-Sky Log

Monday, February 28 6:10 p.m. Date and time	55°F or 12.5°C Temperature
<u>The weather is clear.</u>	
<u>The wind is a gentle breeze.</u>	
<u>Half of the Moon is bright.</u>	

NIGHT-SKY HOME LOG

Name _____

Monday, _____

Date and time

Temperature

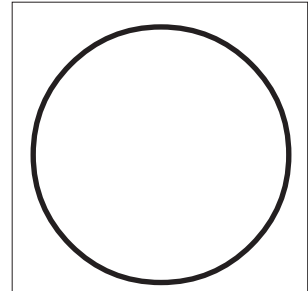

Tuesday, _____

Date and time

Temperature

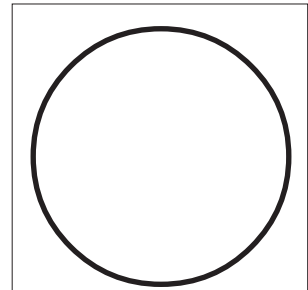

Wednesday, _____

Date and time

Temperature

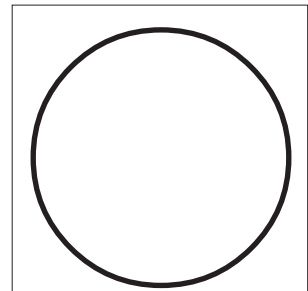

Thursday, _____

Date and time

Temperature

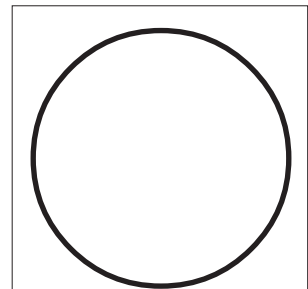

Bring this sheet back to school on Friday morning.

MOON CALENDAR

1. Record the date and time of each observation.
2. Paste a picture of the Moon to show what it looks like each day or night.

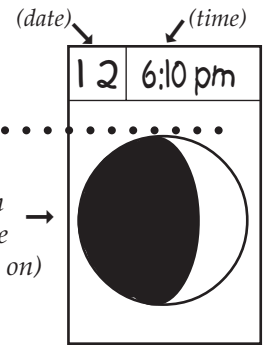









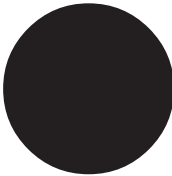
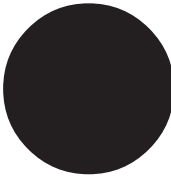

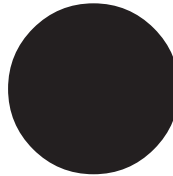

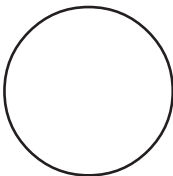
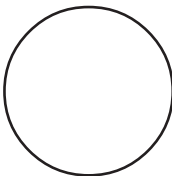
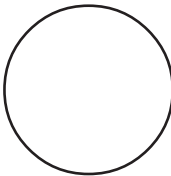
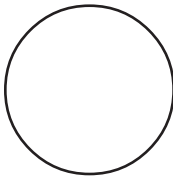
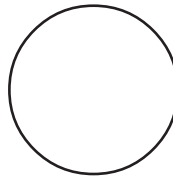
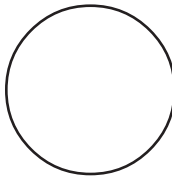

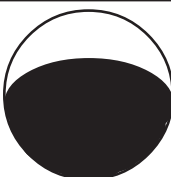



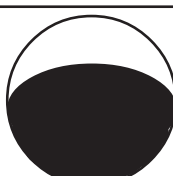

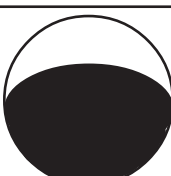

Example

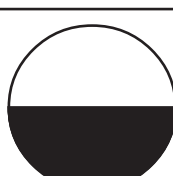
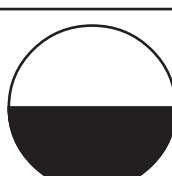
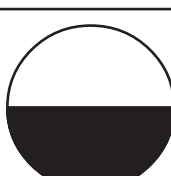
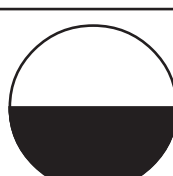
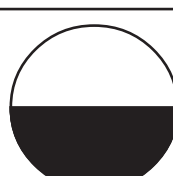
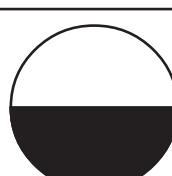
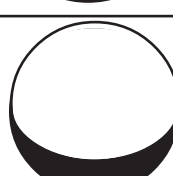
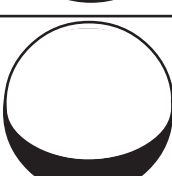
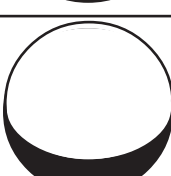
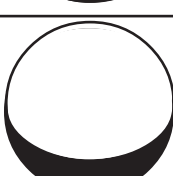
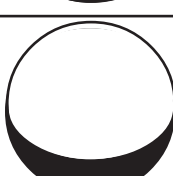
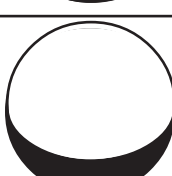
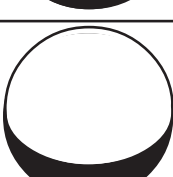
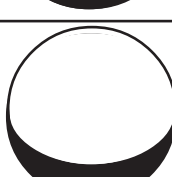
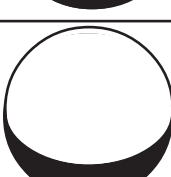
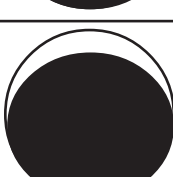
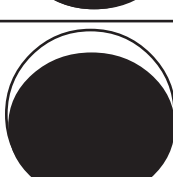
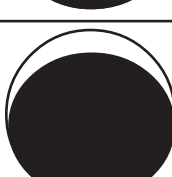
Month: _____

Monday	Tuesday	Wednesday	Thursday	Friday	Saturday	Sunday

CUT-AND-PASTE MOONS

Directions: Cut and sort the Moon pictures. Store them in cups or envelopes for the class meteorologist to choose from each day. (Cut on the straight lines.)

Note to Teachers: Students may need to turn the Moon pictures in different directions in order for them to look like the real Moon in the sky. For example:

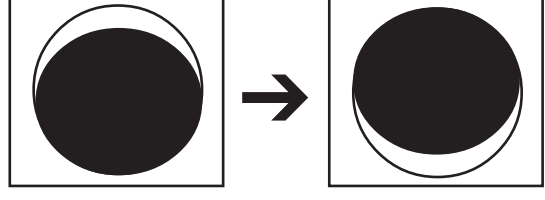

MATH EXTENSION A

INVESTIGATION 1: EXPLORING AIR

Propellers	
Balls	
Rockets	
Our Museum of Air Toys	

Look at the pictures.

Are there more balls or propellers in the museum?

Are there more balls or rockets in the museum?

_____ propellers + _____ rockets = _____ .

_____ balls — _____ propellers = _____ .

Write a number sentence to show how many air toys the museum has all together.

MATH EXTENSION B

Name _____

INVESTIGATION 1: EXPLORING AIR

Ms. Chin wants to set up a learning center.
She has four basins full of water.
Four students can work at each basin.
Ms. Chin has 22 students in her class.

Will all of the students be able to work at the center at the same time?

Name _____

MATH EXTENSION A

INVESTIGATION 2: OBSERVING WEATHER

Count by twos!
What numbers go
in the circles?

What temperature
is it?

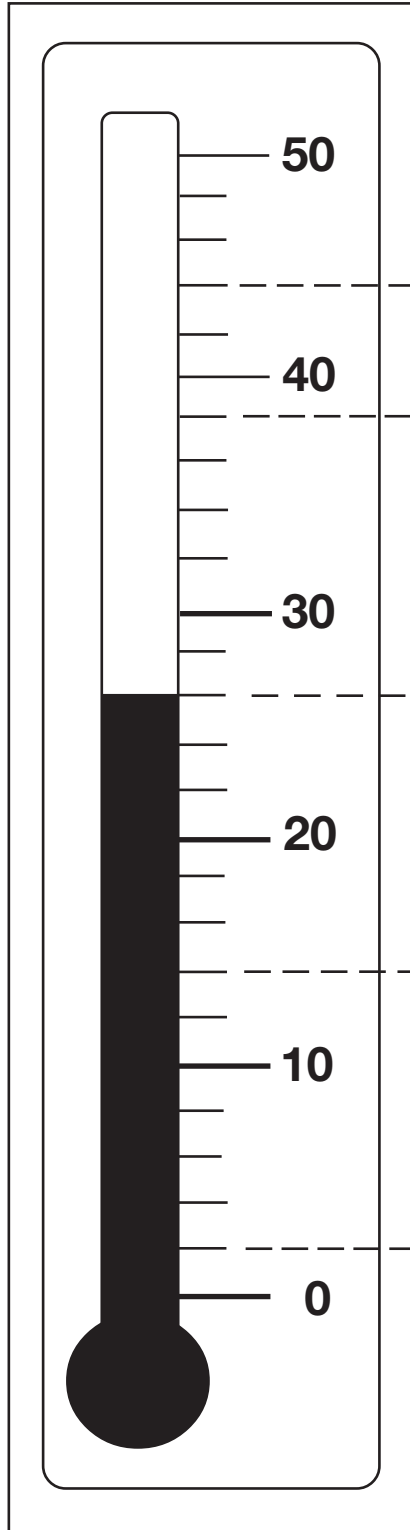

Five large empty circles are arranged vertically. Dashed horizontal lines connect the top of each circle to the thermometer scale at the following values: 50, 40, 30, 20, and 10.

Name _____

MATH EXTENSION B

INVESTIGATION 2: OBSERVING WEATHER

Ms. Long's class put their rain gauge outside to collect water during a big rainstorm. They measured 2 inches of rain from the storm.

Where this class lives, the usual rainfall for the whole year is 26 inches. If all rainstorms brought 2 inches of rain, how many more storms do they need to reach the usual amount of rain for the year?

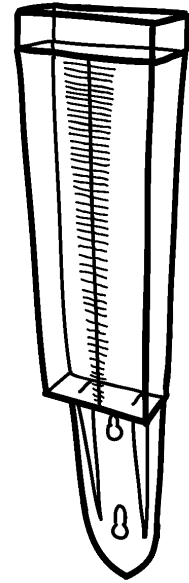

MATH EXTENSION A

INVESTIGATION 3: WIND EXPLORATIONS

Fill in the bar graph to show how fast things move. The first two bars on the graph are already done.

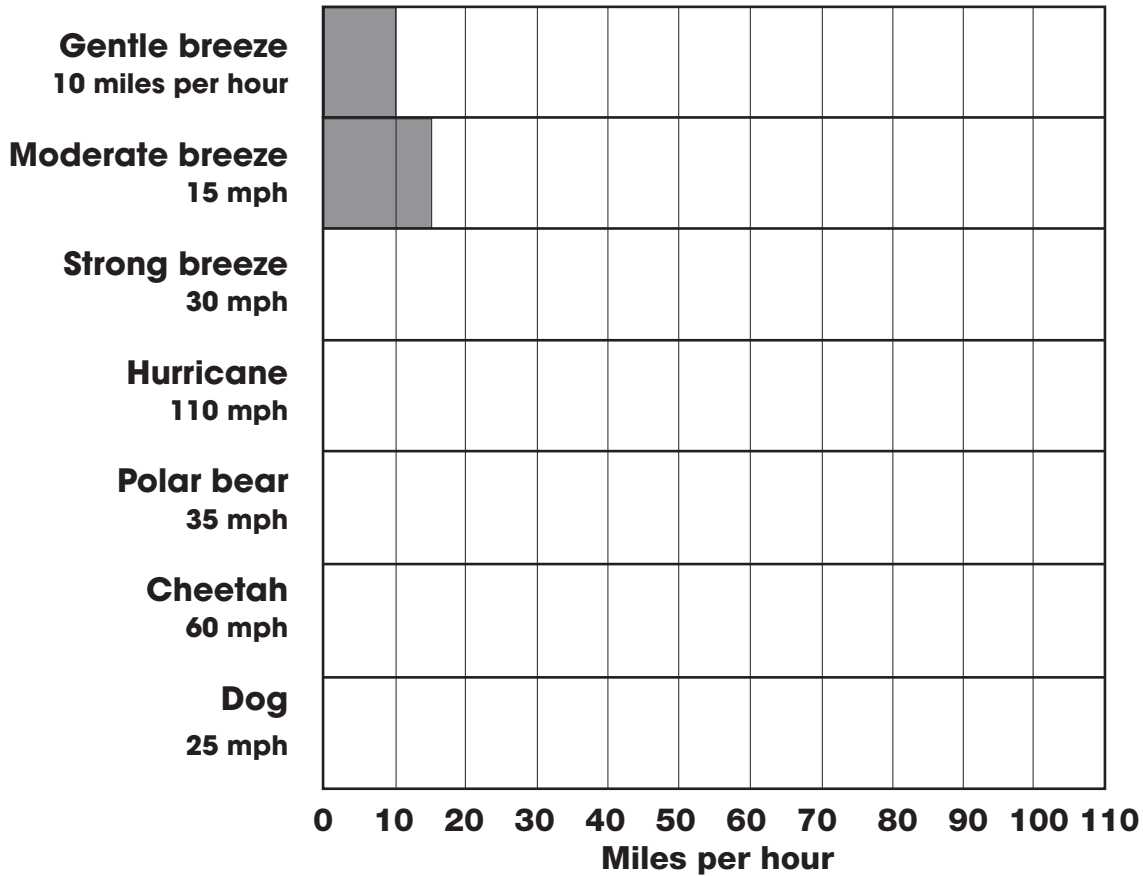

Which is faster?

Use < or > to show which moves faster and slower. For example,

gentle wind strong wind strong wind gentle wind

gentle breeze dog

moderate breeze bear

hurricane cheetah

Name _____

MATH EXTENSION B

INVESTIGATION 3: WIND EXPLORATIONS

Markita wants to have a kite party.
She has 5 friends coming to the party.
Here is what she needs to make 1 kite.

1 piece of paper

3 strings

3 pieces of tape

2 strips of crepe paper for tails

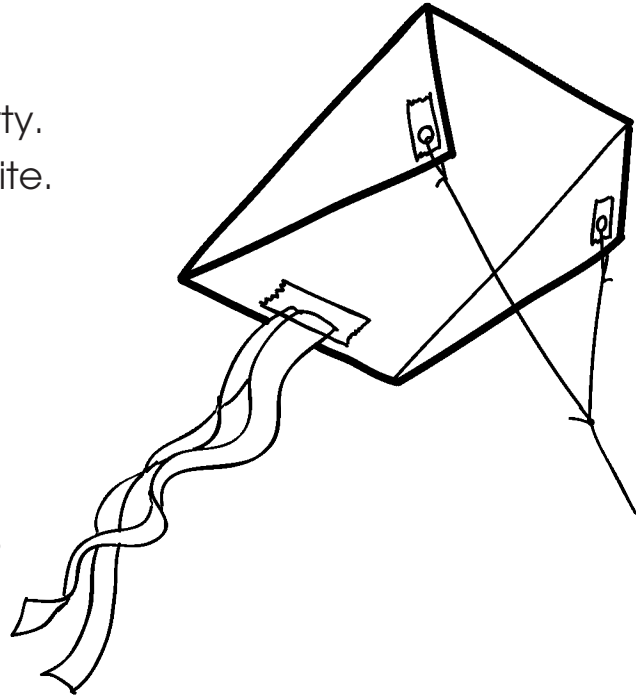

How many pieces of paper, strings, pieces of tape, and strips of crepe paper will she need for 6 kites?

MATH EXTENSION A

Name _____

INVESTIGATION 4: LOOKING FOR CHANGE

Students in three towns recorded the rain that fell in seven storms. Which town had the most rain?

Town	Storm 1	Storm 2	Storm 3	Storm 4	Storm 5	Storm 6	Storm 7
Dripville	1 cm	1 cm	3 cm	5 cm	2 cm	1 cm	2 cm
Puddleton	1 cm	2 cm	2 cm	4 cm	5 cm	1 cm	1 cm
Misty	1 cm	2 cm	4 cm	4 cm	3 cm	2 cm	1 cm

MATH EXTENSION B

INVESTIGATION 4: LOOKING FOR CHANGE

A class in Denver, Colorado, recorded temperatures for 2 weeks during the year. They forgot to label which temperatures went with which month. Make a line graph to show the temperatures recorded for each week, then decide which week was recorded in the winter and which in the summer.

Week 1	
1	40°F
2	25°F
3	20°F
4	35°F
5	40°F
6	50°F
7	55°F

Week 2	
1	80°F
2	90°F
3	90°F
4	95°F
5	80°F
6	85°F
7	75°F

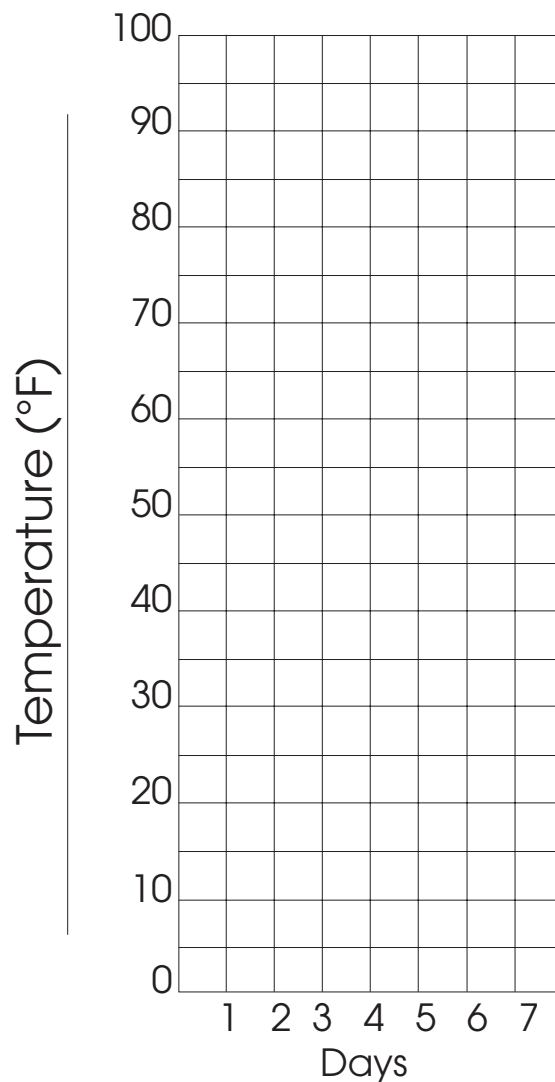
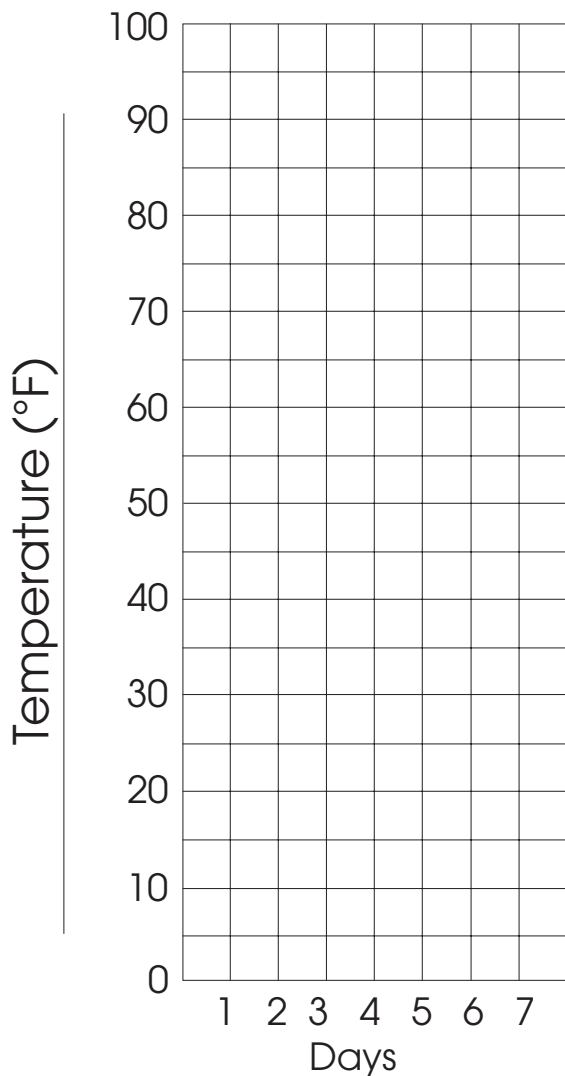

HOME/SCHOOL CONNECTION

Name _____

INVESTIGATION 1: EXPLORING AIR

Air Toys

Look around home and see if you can find a toy that uses air to make it work. If you can't find one, see if you can invent one.

Draw a picture of the toy you found or the one you invented. Explain how it works.

INVESTIGATION 2: OBSERVING WEATHER

Cloud Window

Parents: Make a cloud window with your child using these directions.

1. Cut a 9" × 12" sheet of dark construction paper (shopping bag will do) into four equal strips.

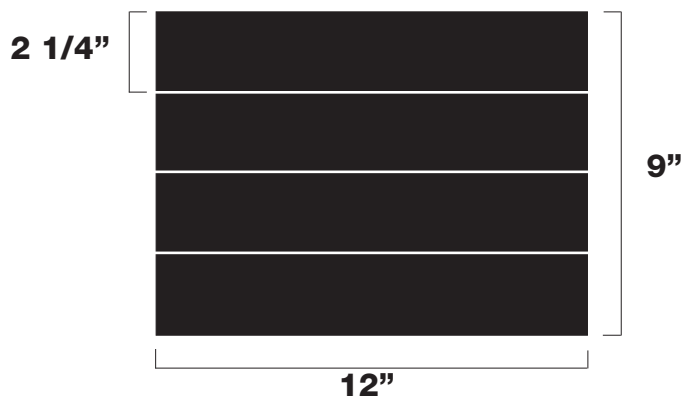

2. Form a rectangle with the four strips, lapping one edge over another about 1/4". Tape it together.



3. Tape the window to a glass window in your house where you will be able to see clouds in the sky.
4. Share your observations with the class next time you go to school.

HOME/SCHOOL CONNECTION

Name _____

INVESTIGATION 3: WIND EXPLORATIONS

Whirligigs

Parents: Make a whirligig with your child using these directions.

Materials: Scissors, tape, and a piece of string

Directions

1. Cut out the whirligig along the spiral line.
2. Tape a piece of string to the X in the middle of the whirligig.
3. Hang the whirligig by the string and blow on it. What does it do?
4. Use the whirligig to find places where the air is moving. Try outside, by a window, or in front of a fan. Where does it move the fastest?

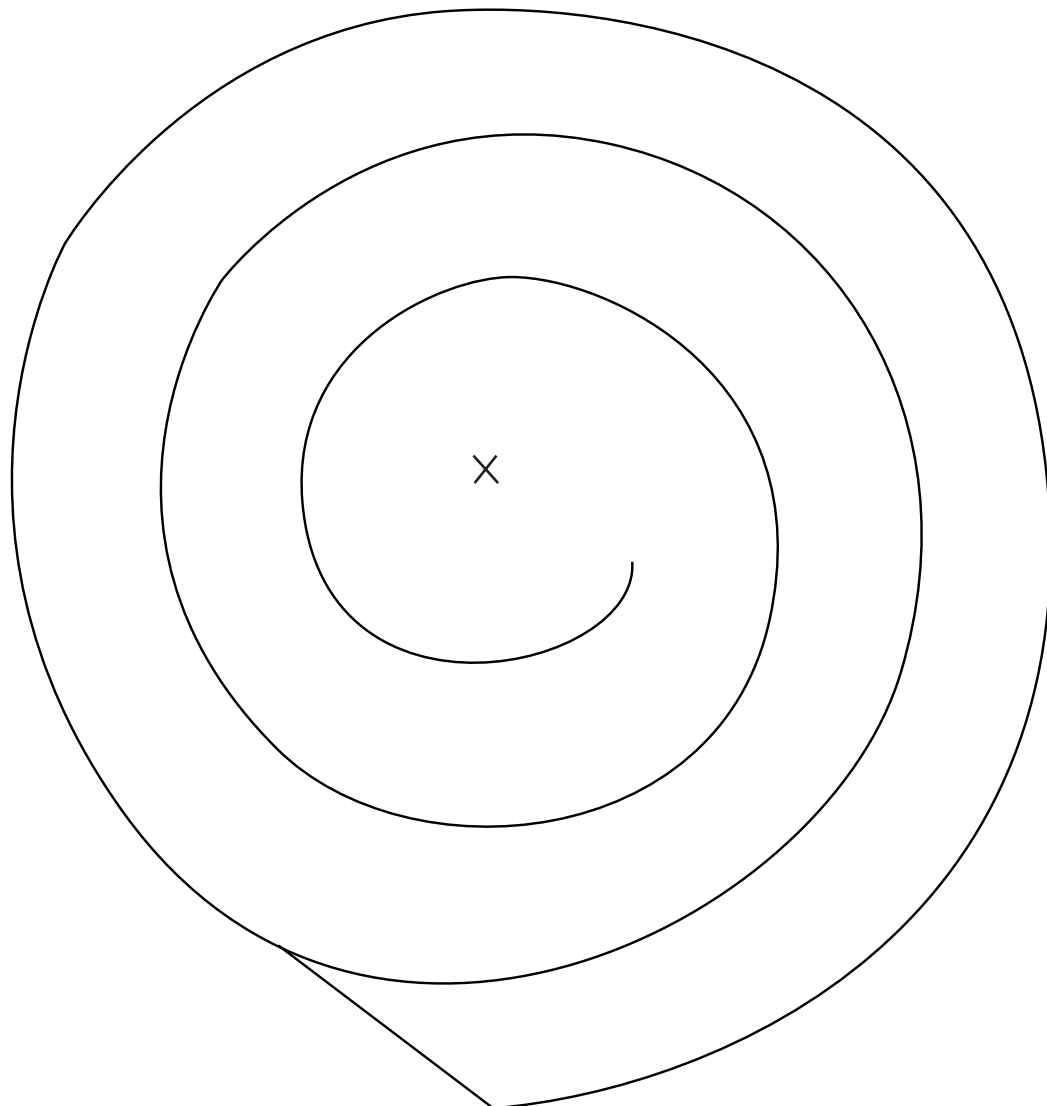

HOME/SCHOOL CONNECTION

Name _____

INVESTIGATION 4: LOOKING FOR CHANGE

Parents: Read this story with your child. Then have him or her draw a picture of Harry in his new clothes.

Harry was always wearing the wrong clothes. When he put on his raincoat, it was warm and sunny outside. When he wore his shorts, the outside temperature was cold. When he decided not to take a jacket with him to school, the wind blew hard.

So Harry decided he wasn't going to go outside. Soon Harry became very, very lonely. All of Harry's friends wanted to play outside. Harry was left alone, wearing the wrong clothes for the weather.

Then Harry got a grand idea! He would design a set of clothes that he could wear outside at any time and in any weather. If it was sunny and warm, Harry could wear his new clothes. If it was windy and rainy, Harry could wear his new clothes. Even if it was snowing, Harry could wear his new clothes!

So, Harry set about designing his new wardrobe.

Finish the story and draw a picture of Harry's all-weather wardrobe.

- What kind of clothing would Harry need?
- What kinds of weather would Harry need to think about?
- How can Harry wear the same thing in all kinds of weather?